

FUSION™

309550ZAM

EN

Plural Component, Impingement Mix Air Purge Spray Gun

For use with non-flammable foam and polyurea. For professional use only.

Not for use in explosive atmospheres.

3500 psi (24.5 MPa, 245 bar) Maximum Fluid Working Pressure

80-130 psi (0.56-0.9 MPa, 5.6-9.0 bar) Air Inlet Pressure Range

200°F (94°C) Maximum Fluid Temperature



Important Safety Instructions

Read all warnings and instructions in this manual.
Save these instructions.

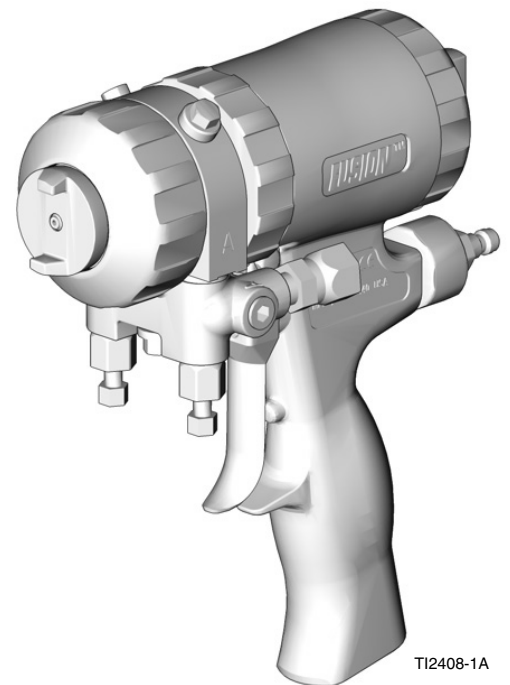

T12408-1A



Contents



- Manual Conventions** 2
- List of Models/Mix Chamber Selection Guide** 3
 - Round Pattern Guns 3
 - Flat Pattern Guns 4
 - Flat Pattern Guns, continued 5
 - Flat Pattern Stud Wall Gun 5
 - Spatter Pattern Gun 6
 - Wide Round Pattern Gun 6
 - Four-Hose Gun 6
 - Non 1:1 Ratio Guns 6
- Overall View** 9
- Important Isocyanate (ISO) Information** 10
 - Material Self-ignition 11
 - Keep Components A and B Separate 11
 - Moisture Sensitivity of Isocyanates 11
 - Foam Resins with 245 fa Blowing Agents 12
 - Changing Materials 12
- Grounding** 12
- Piston Safety Lock** 12
- Turning Air Cap** 13
- Loss of Air Pressure** 13
- Setup** 14
- Shutdown** 16
- Pressure Relief Procedure** 17
- Optional Configurations** 18
 - Optional Fluid Manifold Position 18
 - Optional Hose Position 18
- Flat Spray Tips** 19
- Maintenance** 20
 - Supplied Tool Kit 20
 - Keep Gun Clean 20
 - As Needed 20
 - Daily 20
 - Weekly to Monthly 20

- Flush Gun 21
- Clean Outside of Gun 21
- Clean Air Cap 21
- Clean Muffler 21
- Clean Fluid Manifold 21
- Clean Mix Chamber Nozzle 22
- Clean Passages 22
- Clean Impingement Ports 22
- Troubleshooting** **24**
 - Theory of Operation 26
 - Cutaway View 27
- Repair** **28**
 - Tools Required 28
 - Lubrication 28
 - Remove Front End 28
 - Attach Front End 29
 - Mix Chamber and Side Seal Cartridges 30
 - Check Valves 32
 - Piston 33
 - Piston Safety Lock 34
 - Air Valve 34
- Notes** **35**
- Parts** **36**
 - Mix Chamber Kits 39
 - Flat Tip Kits 40
 - Gun Repair Kits 40
 - Check Valve Filter Screen Kits 40
 - Drill Bit Kits 41
 - Drill Bit Kit 42
 - Air Purge Handle Cleanout Drill Kit 42
- Accessories** **43**
- Technical Data** **47**
- Graco Standard Warranty** **48**
- Graco Information** **48**

Manual Conventions

Warning

 **WARNING**

A warning alerts you to possible serious injury or death if you do not follow instructions.

Symbols, such as fluid injection (shown), alert you to a specific hazard and direct you to read the indicated hazard warnings on pages 7-8.

Caution

CAUTION

A caution alerts you to possible equipment damage or destruction if you do not follow instructions.

Note

 A note indicates additional helpful information.

List of Models/Mix Chamber Selection Guide

Round Pattern Guns

Gun Part No., Series	Mix Chamber				
	Part No.	Impingement Port Size in. (mm)	Equivalent Size	Seal Material	Pattern at 24 in (61 cm) from target in. (mm)
246099, A	AR2020	.020 (0.50)	-000	SST	5 (127)
246100, A	AR2929	.029 (0.70)	-00	SST	8 (203)
248617, A	AR3737	.037 (0.94)	None	SST	9 (227)
246101, A	AR4242	.042 (1.00)	-01	SST	11 (279)
246102, A	AR5252	.052 (1.30)	-02	SST	12 (305)
246103, A	AR6060	.060 (1.50)	-03	SST	14 (356)
246104, A	AR7070	.070 (1.75)	-04	SST	15 (381)
246105, A	AR8686	.086 (2.15)	-05	SST	18 (457)
255201, A	AR4242	.042 (1.00)	-01	Polycarballoy	11 (279)
255202, A	AR5252	.052 (1.30)	-02	Polycarballoy	12 (305)

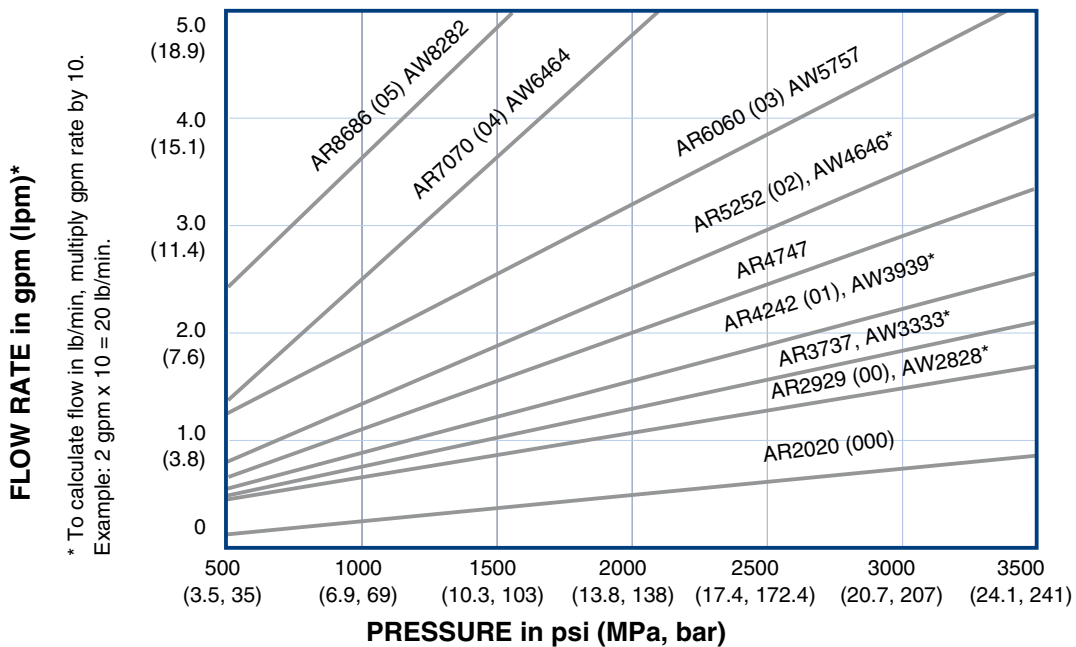

*Accessory AW (wide pattern) mix chambers are available. See page 43.

Flat Pattern Guns

Gun Part No., Series	Mix Chamber			Flat Tip		
	Part No.	Impingement Port Size in. (mm)	Equivalent Size	Part No.	Pattern Size in. (mm)	Orifice Size in. (mm)
247101, A	AF2020	.020 (0.50)	-000	FT0424	8-10 (203-254)	.024 (0.61)
247102, A	AF2020	.020 (0.50)	-000	FT0438	8-10 (203-254)	.038 (0.97)
247103, A	AF2020	.020 (0.50)	-000	FT0624	12-14 (305-356)	.024 (0.61)
247104, A	AF2020	.020 (0.50)	-000	FT0638	12-14 (305-356)	.038 (0.97)
247107, A	AF2020	.020 (0.50)	-000	FT0838	16-18 (406-457)	.038 (0.97)
247108, A	AF2020	.020 (0.50)	-000	FT0848	16-18 (406-457)	.048 (1.22)
247111, A	AF2929	.029 (0.70)	-00	FT0424	8-10 (203-254)	.024 (0.61)
247112, A	AF2929	.029 (0.70)	-00	FT0438	8-10 (203-254)	.038 (0.97)
247113, A	AF2929	.029 (0.70)	-00	FT0624	12-14 (305-356)	.024 (0.61)
247114, A	AF2929	.029 (0.70)	-00	FT0638	12-14 (305-356)	.038 (0.97)
247117, A	AF2929	.029 (0.70)	-00	FT0838	16-18 (406-457)	.038 (0.97)
247118, A	AF2929	.029 (0.70)	-00	FT0848	16-18 (406-457)	.048 (1.22)
247121, A	AF4242	.042 (1.00)	-01	FT0424	8-10 (203-254)	.024 (0.61)
247122, A	AF4242	.042 (1.00)	-01	FT0438	8-10 (203-254)	.038 (0.97)
247123, A	AF4242	.042 (1.00)	-01	FT0624	12-14 (305-356)	.024 (0.61)
247124, A	AF4242	.042 (1.00)	-01	FT0638	12-14 (305-356)	.038 (0.97)
247127, A	AF4242	.042 (1.00)	-01	FT0838	16-18 (406-457)	.038 (0.97)
247128, A	AF4242	.042 (1.00)	-01	FT0848	16-18 (406-457)	.048 (1.22)
247131, A	AF5252	.052 (1.30)	-02	FT0424	8-10 (203-254)	.024 (0.61)
247132, A	AF5252	.052 (1.30)	-02	FT0438	8-10 (203-254)	.038 (0.97)
247133, A	AF5252	.052 (1.30)	-02	FT0624	12-14 (305-356)	.024 (0.61)
247134, A	AF5252	.052 (1.30)	-02	FT0638	12-14 (305-356)	.038 (0.97)
247137, A	AF5252	.052 (1.30)	-02	FT0838	16-18 (406-457)	.038 (0.97)
247138, A	AF5252	.052 (1.30)	-02	FT0848	16-18 (406-457)	.048 (1.22)

Flat Pattern Guns, continued

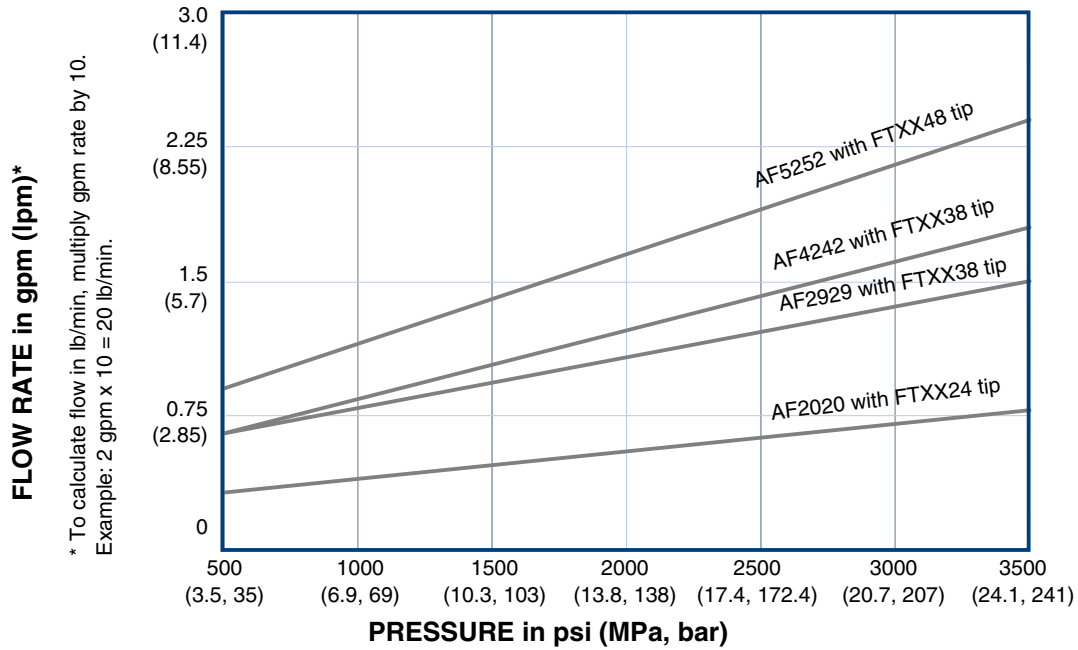

Flat Pattern Stud Wall Gun

See manual number 311071 for more information.

Gun Part No., Series	Mix Chamber			Flat Tip			Flow Data
	Part No.	Impingement Port Size in. (mm)	Equivalent Size	Part No.	Pattern Dia. at 24 in. (610 mm) to Target in. (mm)	Orifice Size in. (mm)	Approximate Flow Rate at 1000 psi (7.0 MPa, 70 bar)
249525	AF4242	.042 (1.00)	-01	FTM979	22 (559)	.038 (0.97)	11 lb/min (4.99 kg/min)
249526	AF5252	.052 (1.30)	-02	FTM979	22 (559)	.038 (0.97)	15 lb/min (6.81 kg.min)

Spatter Pattern Gun

Gun Part No., Series	Mix Chamber		
	Part No.	Impingement Port Size in. (mm)	Equivalent Size
248408 A	AR7070	.070 (1.75)	-04

Wide Round Pattern Gun

Gun Part No., Series	Mix Chamber			Pattern Diameter at 24 in. (610 mm) to Target in. (mm)	Equivalent Flow to Mix Chamber Size Reference Part No.
	Part No.	Impingement Port Size in. (mm)	Equivalent Size		
249529	AW3939	.039 (0.99)	-01	16 (406.4)	AR4242
249530	AW4646	.046 (1.17)	-02	18 (457.2)	AR5252

Four-Hose Gun

Wide Round Pattern Gun with Four-Hose Recirculating Gun Manifold

Gun Part No., Series	Mix Chamber			Pattern Diameter at 24 in. (610 mm) to Target in. (mm)	Approximate Flow Rate at 1000 psi (7.0 MPa, 70 bar)
	Part No.	Impingement Port Size in. (mm)	Equivalent Size		
249810	AW2222	.022 (0.56)	NA	8-9 (203-229)	4.5 lb/min (204 kg/min)

Non 1:1 Ratio Guns

Gun Part No., Series	Mix Chamber
253888	AR2232

WARNING
**PERSONAL PROTECTIVE EQUIPMENT**

Always wear appropriate personal protective equipment and cover all skin when spraying, servicing equipment, or when in the work area. Protective equipment helps prevent serious injury, including long-term exposure; inhalation of toxic fumes, mists or vapors; allergic reaction; burns; eye injury and hearing loss. This protective equipment includes but is not limited to:

- A properly fitting respirator, which may include a supplied-air respirator, chemically impermeable gloves, protective clothing and foot coverings as recommended by the fluid manufacturer and local regulatory authority.
- Protective eyewear and hearing protection.

**TOXIC FLUID OR FUMES HAZARD**

Toxic fluids or fumes can cause serious injury or death if splashed in the eyes or on skin, inhaled or swallowed.

- Read Safety Data Sheet (SDS) for handling instructions and to know the specific hazards of the fluids you are using, including the effects of long-term exposure.
- When spraying, servicing equipment, or when in the work area, always keep work area well ventilated and always wear appropriate personal protective equipment. See **Personal Protective Equipment** warnings in this manual.
- Store hazardous fluid in approved containers, and dispose of it according to applicable guidelines.

**SKIN INJECTION HAZARD**

High-pressure fluid from gun, hose leaks, or ruptured components will pierce skin. This may look like just a cut, but it is a serious injury that can result in amputation. **Get immediate surgical treatment.**

- Do not point the gun at anyone or at any part of the body.
- Do not put your hand or fingers over the gun fluid nozzle.
- Do not stop or deflect leaks with your hand, body, glove, or rag.
- Do not “blow back” fluid; this is not an air spray system.
- Follow **Pressure Relief Procedure**, page 17, when you stop spraying and before cleaning, checking, or servicing equipment.
- Use lowest possible pressure when flushing, priming, or troubleshooting.
- Engage piston safety lock when not spraying.
- Tighten all fluid connections before operating the equipment.
- Check hoses, tubes, and couplings daily. Replace worn or damaged parts immediately. High pressure hose cannot be recoupled; replace the entire hose.

**BURN HAZARD**

Equipment surfaces and fluid that’s heated can become very hot during operation. To avoid severe burns, do not touch hot fluid or equipment. Wait until equipment/fluid has cooled completely.

WARNING
**FIRE AND EXPLOSION HAZARD**

Flammable fumes, such as solvent and paint fumes, in work area can ignite or explode. To help prevent fire and explosion:

- Use equipment only in well ventilated area.
- Eliminate all ignition sources, such as pilot lights, cigarettes, portable electric lamps, and plastic drop cloths (potential static arc).
- Do not plug or unplug power cords or turn lights on or off when flammable fumes are present.
- Keep the work area free of debris, including solvent, rags, and gasoline.
- Ground equipment and conductive objects. See **Grounding**, page 12.
- Hold gun firmly to side of grounded pail when triggering into pail.
- Use only grounded hoses.
- If there is static sparking or you feel a shock, **stop operation immediately**. Do not use equipment until you identify and correct the problem.

**EQUIPMENT MISUSE HAZARD**

Misuse can cause serious injury or death.

- For professional use only.
- Use equipment only for its intended purpose. Call your Graco distributor for information.
- Read manuals, warnings, tags, and labels before operating equipment. Follow instructions.
- Check equipment daily. Repair or replace worn or damaged parts immediately.
- Do not alter or modify equipment. Use only Graco parts and accessories.
- Do not exceed the maximum working pressure or temperature rating of the lowest rated system component. See **Technical Data** in all equipment manuals.
- Use fluids and solvents that are compatible with equipment wetted parts. See **Technical Data** in all equipment manuals. Read fluid and solvent manufacturer's warnings.
- Route hoses and cables away from traffic areas, sharp edges, moving parts, and hot surfaces.
- Do not use hoses to pull equipment.
- Comply with all applicable safety regulations.

**PRESSURIZED ALUMINUM PARTS HAZARD**

Do not use 1,1,1-trichloroethane, methylene chloride, other halogenated hydrocarbon solvents or fluids containing such solvents in pressurized aluminum equipment. Such use can cause serious chemical reaction and equipment rupture, and result in death, serious injury, and property damage.

Overall View

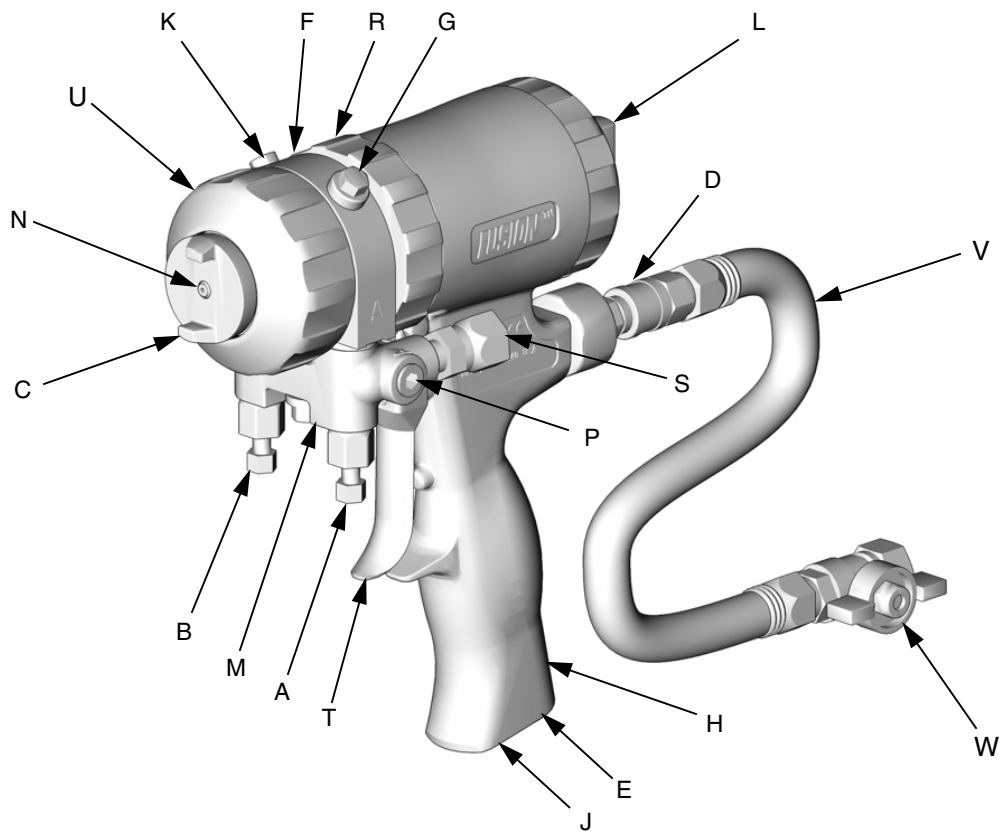

TI2408A





Key:

- A A Side Fluid Valve (ISO)
- B B Side Fluid Valve (RESIN)
- C Air Cap
- D Air Line Quick Coupler
- E Muffler
- F Fluid Housing
- G Grease Fitting (under cap)
- H Handle
- J Optional Air Inlet
- K Cleanoff Air Valve
- L Piston Safety Lock
- M Gun Fluid Manifold
- N Mix Chamber Nozzle
- P Optional Fluid Inlets (A Side Shown)
- R Lock Ring
- S Fluid Inlet Swivels (A Side Shown)
- T Trigger
- U Front Retaining Ring
- V Gun Air Whip Hose
- W Air Valve

Important Isocyanate (ISO) Information



Isocyanates (ISO) are catalysts used in two component materials.

Isocyanate Conditions

									
---	---	---	---	--	--	--	--	--	--

Spraying or dispensing fluids that contain isocyanates creates potentially harmful mists, vapors, and atomized particulates.

- Read and understand the fluid manufacturer’s warnings and Safety Data Sheet (SDS) to know specific hazards and precautions related to isocyanates.
- Use of isocyanates involves potentially hazardous procedures. Do not spray with this equipment unless you are trained, qualified, and have read and understood the information in this manual and in the fluid manufacturer’s application instructions and SDS.
- Use of incorrectly maintained or mis-adjusted equipment may result in improperly cured material which could cause off gassing and offensive odors. Equipment must be carefully maintained and adjusted according to instructions in the manual.
- To prevent inhalation of isocyanate mists, vapors and atomized particulates, everyone in the work area must wear appropriate respiratory protection. Always wear a properly fitting respirator, which may include a supplied-air respirator. Ventilate the work area according to instructions in the fluid manufacturer’s SDS.
- Avoid all skin contact with isocyanates. Everyone in the work area must wear chemically impermeable gloves, protective clothing and foot coverings as recommended by the fluid manufacturer and local regulatory authority. Follow all fluid manufacturer recommendations, including those regarding handling of contaminated clothing. After spraying, wash hands and face before eating or drinking.
- Hazard from exposure to isocyanates continues after spraying. Anyone without appropriate personal protective equipment must stay out of the work area during application and after application for the time period specified by the fluid manufacturer. Generally this time period is at least 24 hours.
- Warn others who may enter work area of hazard from exposure to isocyanates. Follow the recommendations of the fluid manufacturer and local regulatory authority. Posting a placard such as the following outside the work area is recommended:

 WARNING	
	TOXIC FUMES HAZARD
DO NOT ENTER DURING SPRAY FOAM APPLICATION OR FOR ___ HOURS AFTER APPLICATION IS COMPLETE	
DO NOT ENTER UNTIL:	
DATE: _____	
TIME: _____	

For all applications except spray foam



Spraying or dispensing fluids that contain isocyanates creates potentially harmful mists, vapors, and atomized particulates.

- Read and understand the fluid manufacturer's warnings and Safety Data Sheet (SDS) to know specific hazards and precautions related to isocyanates.
- Use of isocyanates involves potentially hazardous procedures. Do not spray with this equipment unless you are trained, qualified, and have read and understood the information in this manual and in the fluid manufacturer's application instructions and SDS.
- Use of incorrectly maintained or mis-adjusted equipment may result in improperly cured material. Equipment must be carefully maintained and adjusted according to instructions in the manual.
- To prevent inhalation of isocyanate mists, vapors, and atomized particulates, everyone in the work area must wear appropriate respiratory protection. Always wear a properly fitting respirator, which may include a supplied-air respirator. Ventilate the work area according to instructions in the fluid manufacturer's SDS.

Avoid all skin contact with isocyanates. Everyone in the work area must wear chemically impermeable gloves, protective clothing and foot coverings as recommended by the fluid manufacturer and local regulatory authority. Follow all fluid manufacturer recommendations, including those regarding handling of contaminated clothing. After spraying, wash hands and face before eating or drinking.

Material Self-ignition



Some materials may become self-igniting if applied too thick. Read material manufacturer's warnings and Safety Data Sheet (SDS).

Keep Components A and B Separate



Cross-contamination can result in cured material in fluid lines which could cause serious injury or damage equipment. To prevent cross-contamination:

- **Never** interchange component A and component B wetted parts.
- Never use solvent on one side if it has been contaminated from the other side.

Moisture Sensitivity of Isocyanates

Exposure to moisture (such as humidity) will cause ISO to partially cure, forming small, hard, abrasive crystal that become suspended in the fluid. Eventually a film will form on the surface and the ISO will begin to gel, increasing in viscosity.

NOTICE

Partially cured ISO will reduce performance and the life of all wetted parts.

- Always use a sealed container with a desiccant dryer in the vent, or a nitrogen atmosphere. **Never** store ISO in an open container.
- Keep the ISO pump wet cup or reservoir (if installed) filled with appropriate lubricant. The lubricant creates a barrier between the ISO and the atmosphere.
- Use only moisture-proof hoses compatible with ISO.
- Never use reclaimed solvents, which may contain moisture. Always keep solvent containers closed when not in use.
- Always lubricate threaded parts with an appropriate lubricant when reassembling.

NOTE: The amount of film formation and rate of crystallization varies depending on the blend of ISO, the humidity, and the temperature.

Foam Resins with 245 fa Blowing Agents

Some foam blowing agents will froth at temperatures above 90°F (33°C) when not under pressure, especially if agitated. To reduce frothing, minimize preheating in a circulation system.

Changing Materials

NOTICE

Changing the material types used in your equipment requires special attention to avoid equipment damage and downtime.

- When changing materials, flush the equipment multiple times to ensure it is thoroughly clean.
- Always clean the fluid inlet strainers after flushing.
- Check with your material manufacturer for chemical compatibility.
- When changing between epoxies and urethanes or polyureas, disassemble and clean all fluid components and change hoses. Epoxies often have amines on the B (hardener) side. Polyureas often have amines on the B (resin) side.

Grounding

WARNING



Read warnings, page 8.

Check your local electrical code and proportioner manual for detailed grounding instructions.

Ground the spray gun through connection to a Graco-approved grounded fluid supply hose.

Piston Safety Lock

Engage piston safety lock whenever you stop spraying, to avoid accidental triggering.

WARNING



Read warnings, page 7.

To engage piston safety lock: push knob in and turn clockwise. If engaged, gun will not actuate.

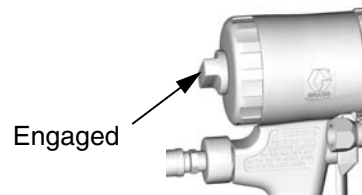

TI2409A

To disengage piston safety lock: push knob in and turn counterclockwise until it pops out. There will be a gap between knob and gun body.

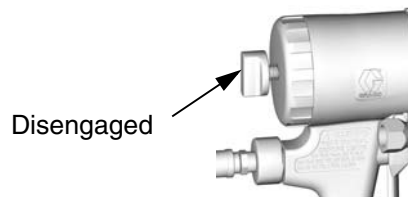

TI2410A

Turning Air Cap

⚠ WARNING



Read warnings, page 7.

1. Follow **Pressure Relief Procedure**, page 17.
2. Close fluid valves A and B before turning air cap (C).

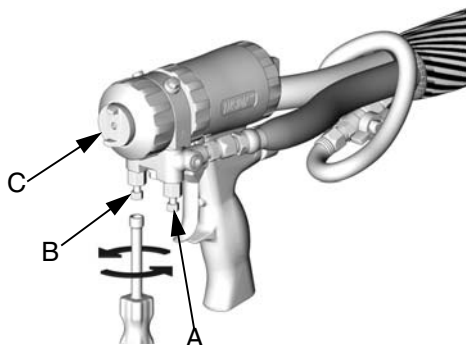

T12421A

Loss of Air Pressure

In event of loss of air pressure, gun will continue to spray. To shut off gun, do one of the following:

- Push in piston safety lock, see page 12.
- Close fluid valves A and B.

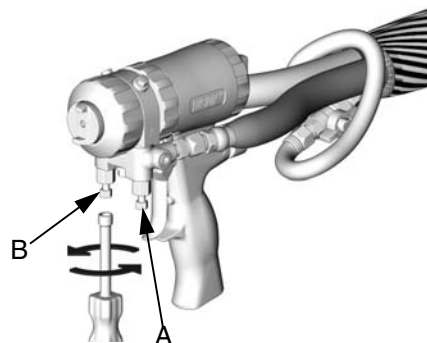

T12421A

Setup

1. Close fluid valves A and B.

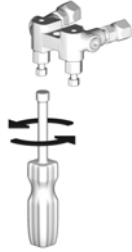

TI2411A

2. Connect A (ISO) and B (RESIN) fluid hoses to fluid manifold.

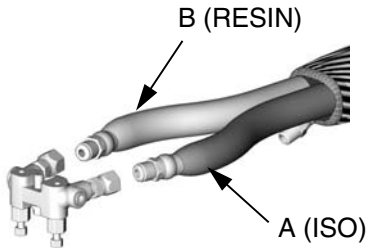

TI2417A

3. Engage piston safety lock, page 12.



TI2409A

4. Connect gun air whip hose (V) and air valve (W*) to main air hose. Attach fluid manifold (M) to gun.

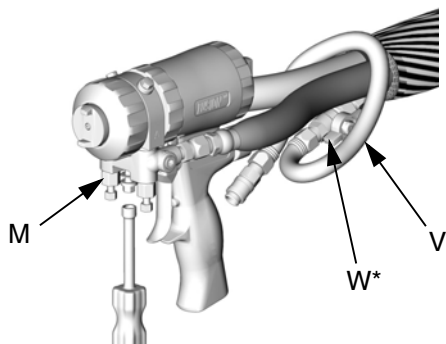

TI2554A

5. Connect quick coupler (D). Turn on air. Open air valve (W*). Air should flow from nozzle (N).

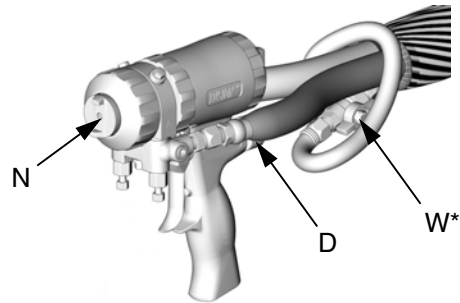

TI2414-1A

 To use optional air inlet, see page 18.

6. Disengage piston safety lock, page 12.



TI2410A

7. Trigger gun to check for full mix chamber travel. Front of air cap (C) should be approximately flush with front retaining ring (U).

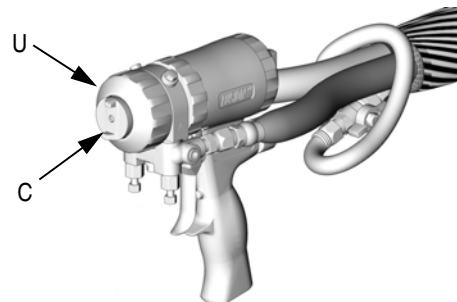

TI2414-1A

* (W) Not included with spatter gun.

 To change position of fluid manifold or use optional fluid inlets, see pages 18 and 18.

8. Open cleanoff air valve (K) 1/4-1/2 turn and trigger gun to check that cleanoff air is flowing. Adjust as desired. This step does not apply with spatter spray gun 248408.

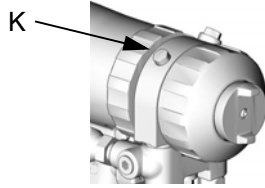

TI2413A

9. Engage piston safety lock, page 12.



TI2409A

10. Turn on proportioner.

11. Open B (RESIN) fluid valve (about three half turns). Then open A (ISO) fluid valve.

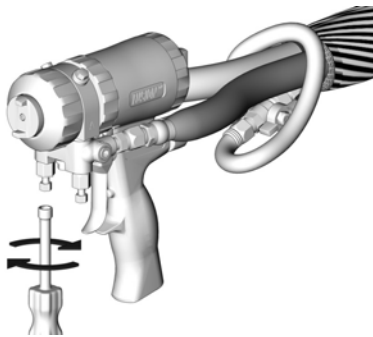

TI2414A

12. Disengage piston safety lock, page 12.



TI2410A

13. Test spray onto cardboard. Adjust pressure and temperature to get desired results.

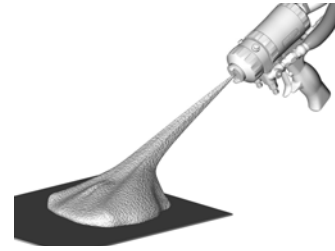

TI2645A

14. Apply layer of lubricant over front of gun and lock ring, or use gun cover to prevent overspray buildup and ease disassembly. See page 45 to order lubricant and gun cover.

15. Gun is ready to spray.

CAUTION

Air supply is required for gun actuation. Do not disconnect gun air supply until fluid pressure is relieved, page 17.

Shutdown

For overnight shutdown:

1. Follow **Pressure Relief Procedure**, page 17.
2. Leave air turned on and gun detriggered.

 Grease gun daily to prevent 2 component curing and keep fluid passages clean. Purge air carries grease mist through air chamber (AC), impingement ports (IP), and out mix chamber nozzle (N), coating all surfaces. Use Graco 117773 Grease, see page 45.

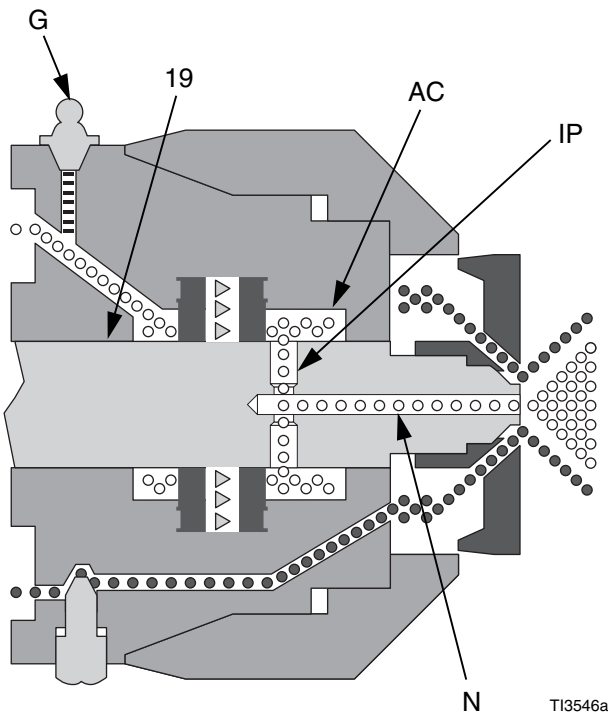
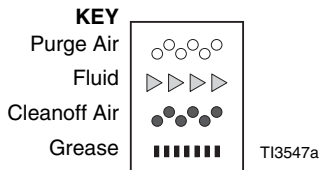

3. Remove grease fitting cap. Using grease gun (Y), dispense grease into fitting (G) until grease mist sprays from mix chamber nozzle (N). Do not over-grease; use 2 shots maximum. Do not spray grease mist on sprayed material.

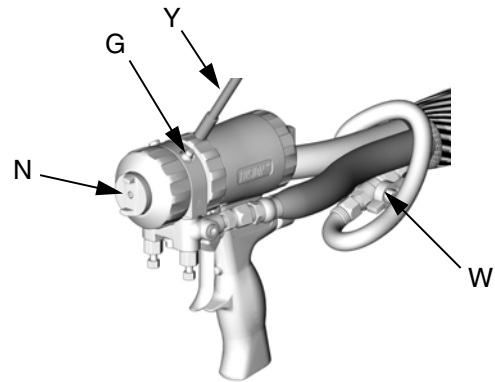

4. Replace grease cap.
5. *Round and Flat pattern guns only:* Turn off air valve (W).
Spatter pattern gun only: Shut down main air supply.

Pressure Relief Procedure

WARNING



Read warnings, page 7. Relieve pressure before cleaning or repairing gun.

1. Engage piston safety lock, page 12.



TI2409A

CAUTION

Air supply is required for gun actuation. Do not disconnect gun air supply until fluid pressure is relieved.

2. Close fluid valves A and B. Leave air valve (W) open.

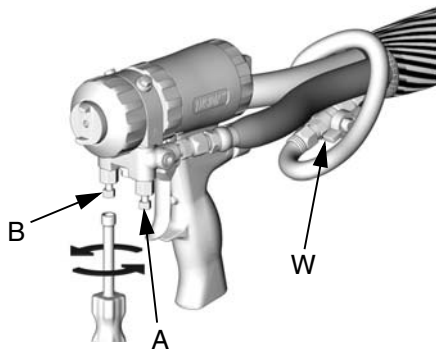

TI2421A

3. Disengage piston safety lock, page 12.



TI2410A

4. Trigger gun onto cardboard or into waste container to relieve pressure.



TI4722a

5. Engage piston safety lock, page 12.



TI2409A

WARNING



Fluid in the hose and proportioner is still under pressure. Follow the Pressure Relief Procedure in the proportioner manual.

To relieve pressure in the hose after the gun is removed, place the fluid manifold over containers, facing away from you. Very carefully open the fluid valves. Under high pressure, fluid will spray sideways from the fluid ports.

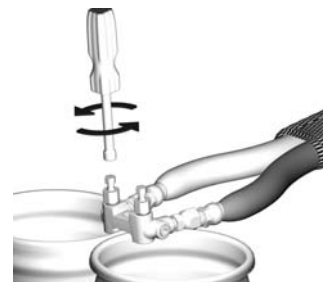

TI2484A

Optional Configurations

Optional Fluid Manifold Position

Fluid manifold is mounted to bottom of gun, with A side on left, viewed from operator's position at back of gun. If desired, manifold may be moved to top of gun. Doing this will reposition A side parts (fluid inlet swivel, check valve, side seal cartridge, and mix chamber) to right.

CAUTION

To prevent cross-contamination of gun's wetted parts, do not interchange A component (isocyanate) and B component (resin) parts.

1. Follow **Pressure Relief Procedure**, page 17.
2. Disconnect air (D) and remove fluid manifold (M).

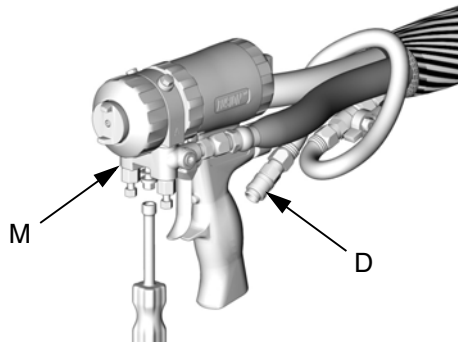

TI2554A

3. **Remove Front End**, page 28.
4. Rotate fluid housing 180°.
5. **Attach Front End**, page 29.
6. Attach fluid manifold. Connect air. Return gun to service.

Optional Hose Position

Fluid inlet swivels and air quick disconnect fitting point to rear. If desired, these positions can be changed so hoses travel downward.

CAUTION

To prevent cross-contamination of gun's wetted parts, do not interchange A component (isocyanate) and B component (resin) parts.

1. Follow **Pressure Relief Procedure**, page 17. Also relieve system pressure, see proportioner manual.
2. Disconnect air (D) and remove fluid manifold (M).

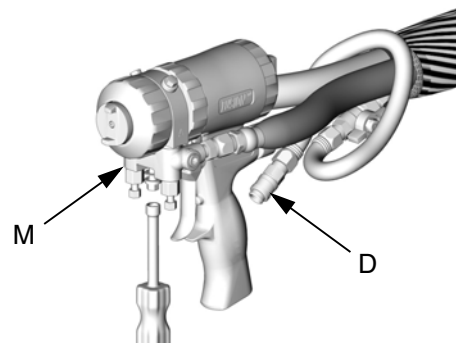

TI2554A

3. Disconnect fluid hoses from inlet swivels (A, B). Remove swivels. Remove plugs from optional inlets (P).

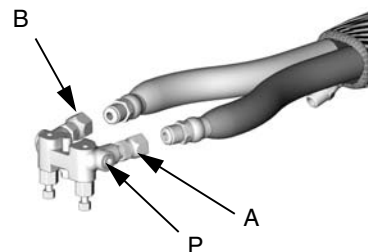

TI2417A

- Apply thread sealant to plugs (12c), elbows (50*), and male threads of swivels (A, B). Install elbows (50*) in optional inlets (P), facing down. Install swivels (A, B) in elbows. Be sure to install A swivel (smaller) in A side. Install plugs where swivels had been. Torque all parts to 235-245 in-lb (26.6-27.7 N•m).

 Elbows (50*) are not included with spatter spray gun.

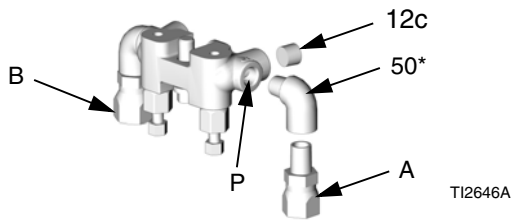

- Connect A and B hoses to A and B swivels.
- Remove fitting (D) and plug (J). Reverse positions. Apply thread sealant and torque to 125-135 in-lb (14-15 N•m).

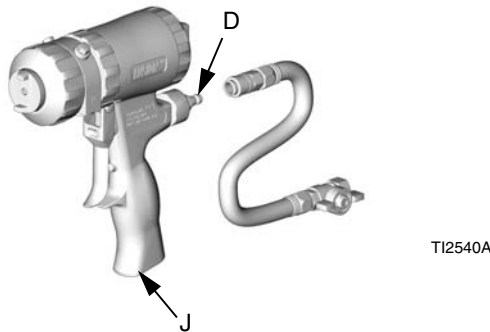

- Attach fluid manifold. Connect air. Return gun to service.

Flat Spray Tips

- Follow **Pressure Relief Procedure**, page 17.
- Remove air cap (10) and flat spray tip (39). Inspect o-ring (40).

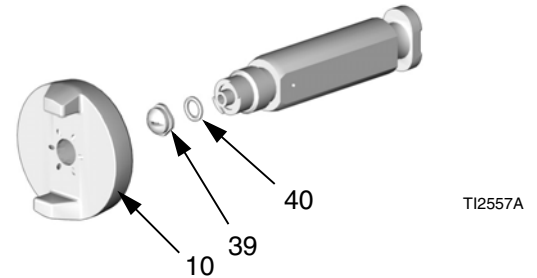

 If tip is stuck, pry off with small screwdriver or pull off with pliers. Tip is hardened to resist damage.

- To clean, soak tip in compatible solvent, see page 21. Clean gently with tip cleanout tool 15D234, page 45, to fit tip configuration.
- Reposition tip horizontally or vertically, or install different tip size.

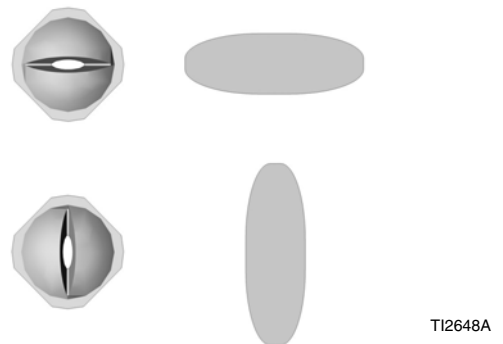
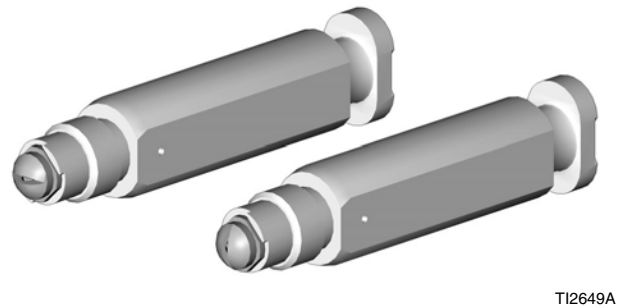

 Tips marked on back with last 3 digits of part no. See **Flat Tip Part No. Reference Guide**, page 40.

- Reinstall air cap hand tight. Cleaning hole alignment to tip not important.

Maintenance

Supplied Tool Kit

- Hex Nut Driver; 5/16
- Screwdriver; 1/8 blade
- Nozzle Drill Bit; various sizes depending on nozzle size. See TABLE 1, page 22.
- Impingement Port Drill Bit; various sizes depending on port size. See TABLE 3, page 23.
- 117661 Pin Vise; dual reversible chucks



- 551189 Grease Gun; with 3 oz grease
- 15B817 Flush Manifold
Not included with spatter spray gun.

Keep Gun Clean

Keep gun clean with accessory gun cover, page 42.

Applying a light coat of lubricant will make cleaning easier.

As Needed

1. **Clean Outside of Gun**, page 21.
2. **Clean Mix Chamber Nozzle**, page 22, a minimum of once a day.
3. **Clean Air Cap**, page 21.
4. **Clean Muffler**, page 21.
5. **Clean Fluid Manifold**, page 21.
6. **Clean Passages**, page 22.
7. **Clean Impingement Ports**, page 22.

Daily

Follow **Shutdown**, page 16.

Weekly to Monthly

1. Clean **Mix Chamber and Side Seal Cartridges**, page 30. Check o-rings.
2. Clean **Check Valves**, page 32. Check o-rings and filters.

Flush Gun

If it is necessary to flush gun, use following procedure.

<p>⚠ WARNING</p> 
<p>Read warnings, page 8.</p>

1. Follow **Pressure Relief Procedure**, page 17.
2. Flush with compatible solvent into a grounded metal pail, holding a metal part of fluid manifold firmly to side of pail. Use the lowest possible fluid pressure when flushing.
3. Follow **Pressure Relief Procedure**, page 17.



For a more thorough flush, Solvent Flush Kit 218669 is available as an accessory. The kit connects to Flush Manifold 15B817.

Clean Outside of Gun

Wipe off outside of gun with compatible solvent.

Use N Methyl Pyrrolidone (NMP), Dynasolve CU-6, Dzolv, or equivalent to soften cured material.

CAUTION
These solvents are not recommended for flushing.

Clean Air Cap

Soak air cap in compatible solvent. Clean holes with #58 (.042) drill bit.

Clean Muffler

Remove and clean muffler with compatible solvent.

Clean Fluid Manifold

Clean fluid manifold sealing faces with compatible solvent and a brush whenever removed from gun. Be sure to clean the two fluid ports (X) in the top mating surface. Do not damage the flat sealing surfaces. Coat with grease if left exposed, to seal out moisture.

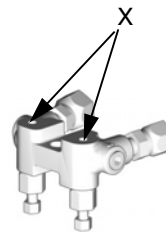

TI2411-1

Clean Mix Chamber Nozzle

1. Engage piston safety lock, page 12.



TI2409A

2. Refer to TABLE 1. Also see identification chart under **Drill Bit Kits**, page 41. Use the appropriate size drill bit to clean mix chamber nozzle (N). If necessary, clean air cap (C) gently with stiff brush.

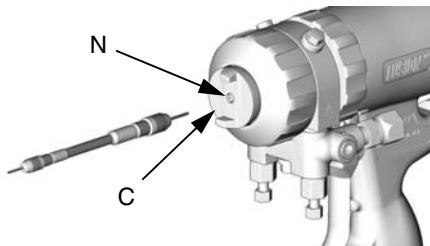

TI2418A

Table 1: Nozzle Drill Bit Sizes

Round Spray		Flat Spray	
Mix Chamber Part No.	Drill Size in. (mm)	Mix Chamber Part No.	Drill Size in. (mm)
AR2020	#58, .042 (1.00)	AF2020	3/32, .094 (2.35)
AR2929	#55, .052 (1.30)	AF2929	3/32, .094 (2.35)
AR3737	#55, .052 (1.30)		
AR4242	#53, .060 (1.50)	AF4242	3/32, .094 (2.35)
AR4747	1/16, .0625 (1.59)		
AR5252	#50, .070 (1.75)	AF5252	3/32, .094 (2.35)
AR6060	#44, .086 (2.15)		
AR7070	3/32, .094 (2.35)		
AR8686	#32, 0.116 (2.90)		

Round Spray		Flat Spray	
Mix Chamber Part No.	Drill Size in. (mm)	Mix Chamber Part No.	Drill Size in. (mm)
AR2237	0.47 (1.2)	AF2033	3/32, .094 (2.35)
AR2924	#55, .052 (1.30)	AF2942	3/32, .094 (2.35)
AR3729	#55, .052 (1.3 mm)		

Clean Passages

If necessary, clean out passages in fluid housing and handle with drill bits. Refer to TABLE 2 and to **Cutaway View** on page 27 for diameter and location of passages. All drill bits are available in an accessory kit. Order kit 248969 for Air Purge Handle Drill Kit, see page 42.

Table 2: Passage Diameters

Passage Description	Ref. Letter (page 27)	Diameter, in. (mm)
Optional Air Inlet	C	7/16, 1/8 (11.0, 3.1)
Purge Air	D	1/8 (3.1)
Piston Air	E, F	1/8 (3.1)
Air Exhaust	G	11/32, 1/8 (8.7, 3.1)
Air Valve Bore	H	9/32 (7.1)
Cleanoff Air	Not Shown	3/32 (2.35)
Check Valve Holes	Not Shown	3/32 (2.35)
Grease	Not Shown	3/32 (2.35)

Clean Impingement Ports

1. Follow **Pressure Relief Procedure**, page 17.
2. Disconnect air (D) and remove fluid manifold (M).

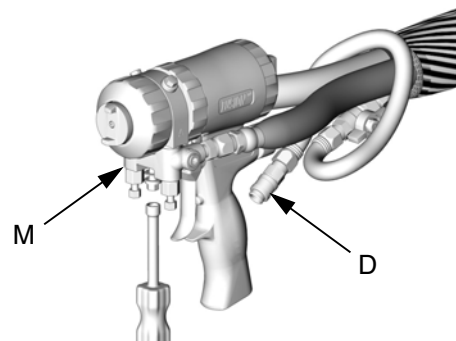

TI2554A

3. **Flush Gun**, page 21. If gun will not flush, see page 30.

4. **Remove Front End**, page 28.
5. Push mix chamber forward until impingement ports (IP) are visible. See TABLE 3 for appropriate size drill to clean ports. Also see identification chart under **Drill Bit Kits**, page 41. Some mix chambers have counterbored holes (CB) and require two drill sizes to clean impingement ports completely.

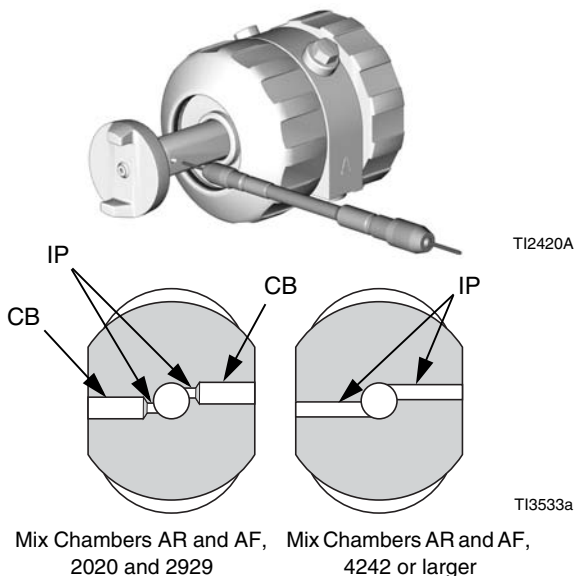

Table 3: Impingement Port Drill Bit Sizes

Mix Chamber Part No.	Impingement Port (IP) Drill Bit Size in. (mm)	Counterbore (CB) Drill Bit Size in. (mm)
AR2020	#76, .020 (0.50)	#53, .060 (1.50)
AR2929	#69, .029 (0.70)	#53, .060 (1.50)
AR3737	#63, .037 (0.94)	N/A
AR4242	#58, .042 (1.00)	N/A
AR4747	#56, .0165 (1.18)	N/A
AR5252	#55, .052 (1.30)	N/A
AR6060	#53, .060 (1.50)	N/A
AR7070	#50, .070 (1.75)	N/A
AR8686	#44, .086 (2.15)	N/A
AF2020	#76, .020 (0.50)	#53, .060 (1.50)
AF2929	#69, .029 (0.70)	#53, .060 (1.50)
AF4242	#58, .042 (1.00)	N/A
AF5252	#55, .052 (1.30)	N/A
Non 1:1 Ratio Mix Chamber Kits		
Mix Chamber Part No.	Impingement Port (IP) Drill Bit Size in. (mm)	Counterbore (CB) Drill Bit Size in. (mm)
AR2232	#74, .023 (0.59) #61, .032 (0.81)	#53, .060 (1.50)
AR2942	#58, .042 (1.07) #69, .029 (.74)	#53, .060 (1.50)
AR3729	#63, .037 (0.94) #69, .029 (.74)	#53, .060 (1.50)
AF2033	#76, .020 (.50) #66, .033 (.84)	#53, .060 (1.50)
AF2942	#69, .029 (.74) #58, .042 (1.07)	#53, .060 (1.50)

6. Push mix chamber back in position.
7. **Attach Front End**, page 29.
8. Attach fluid manifold. Connect air. Return gun to service.

Troubleshooting

1. Follow **Pressure Relief Procedure**, page 17, before checking or repairing gun.
2. Check all possible problems and causes before disassembling gun.

CAUTION
To prevent cross-contamination of the gun's wetted parts, do not interchange A component (isocyanate) and B component (resin) parts.

PROBLEM	CAUSE	SOLUTION
Gun does not fully actuate when triggered.	Safety lock engaged.	Disengage safety lock, page 12.
	Plugged muffler (22).	Clean, page 21.
	Damaged air valve o-rings (24).	Replace, page 34.
Fluid does not spray when gun is fully actuated.	Closed fluid valves (12b).	Open.
	Plugged impingement ports.	Clean, page 22.
	Plugged check valves (26).	Clean, page 32.
Gun actuates slowly.	Plugged muffler (22).	Clean, page 21.
	Damaged piston o-rings (16, 17).	Replace, page 33.
	Dirty air valve, or damaged o-rings (24).	Clean air valve or replace o-rings, page 34.
Gun delays, then actuates abruptly.	Cured material around side seals (18).	Inspect side seals (18c) and mix chamber (19) for scratches. Replace, page 30.
	Retaining ring (9) not bottomed out.	Tighten retaining ring until bottomed out.
Loss of round pattern.	Dirty mix chamber nozzle.	Clean, page 22.
Loss of flat pattern.	Plugged spray tip.	Clean in compatible solvent, page 19.
	Worn tip.	Replace, page 19.
	Dirty mix chamber nozzle.	Clean, page 22.
Leakage between flat tip and mix chamber.	Tip not seated properly.	Reassemble, page 19.
	Damaged/missing o-ring (40).	Replace, page 19.
Pressure imbalance.	Plugged impingement ports.	Clean, page 22.
	Plugged check valves (26).	Clean, page 32.
	Viscosities not equal.	Adjust temperature to compensate.

PROBLEM	CAUSE	SOLUTION
A and/or B fluid in gun air section.	Damaged side seals (18c).	Replace, page 30.
	Damaged mix chamber (19).	Replace, page 30.
	Damaged side seal o-rings (18d, 18e).	Replace, page 30.
	Tightened air cap with fluid valves (12b) open.	Close valves first.
Fluid mist from mix chamber or air cap.	Damaged side seals (18c).	Replace, page 30.
	Damaged side seal o-rings (18d, 18e).	Replace, page 30.
	Damaged mix chamber (19).	Replace, page 30.
Excessive overspray.	Too much cleanoff air.	Reduce, page 15.
Rapid buildup of material on air cap.	Plugged air cap holes.	Clean, page 21.
	Too little cleanoff air.	Increase, page 15.
	Damaged/missing fluid housing o-ring (23).	Replace, page 30.
	Damaged front o-ring (3).	Replace, page 30.
Reduced cleanoff air.	Damaged front o-ring (3).	Replace, page 30.
Excessive cleanoff air when fluid valves are closed and gun is triggered.	Damaged/missing fluid housing o-ring (23).	Replace, page 30.
Fluid does not shut off when fluid valves are closed.	Damaged fluid valves (12b).	Replace.
Burst of air from muffler when gun is triggered.	Normal.	No action required.
Steady air leakage from muffler.	Damaged air valve o-rings (24).	Replace, page 34.
	Damaged piston o-rings (16, 17).	Replace, page 33.
Air leakage from front air valve.	Damaged air valve o-rings (24).	Replace, page 34.
Air leak around lock ring.	Damaged o-ring (21).	Replace, page 30.
Cannot tighten retaining ring (9) until it bottoms out.	Air cap (10) assembled before retaining ring (9).	Install retaining ring (9) first, then air cap (10), page 31.

Theory of Operation

Gun Triggered (Fluid Spraying)

Mix chamber (19) moves back, shutting off purge air flow. Impingement ports (IP) align with fluid ports of side seals (18c), allowing fluid to flow through mix chamber nozzle (N).

See page 15 to adjust cleanoff air valve (K).

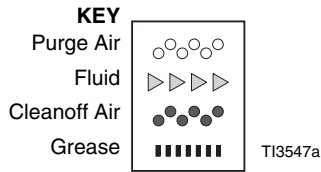

Flow paths are not shown to scale, for clarity.

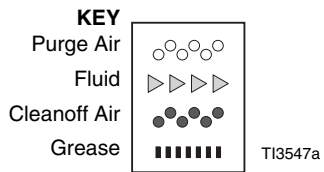
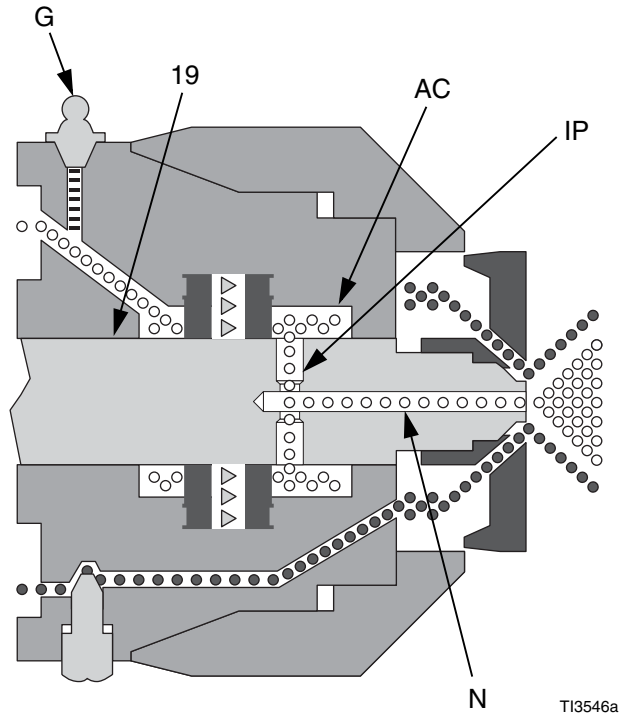

Flow paths are not shown to scale, for clarity.

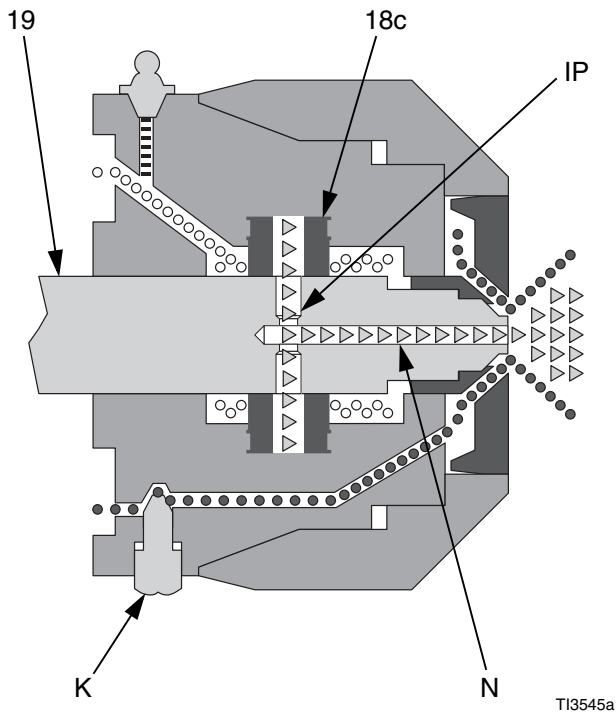

Gun Detriggered (Air Purging)

Mix chamber (19) moves forward, shutting off fluid flow. Impingement ports (IP) open to air chamber (AC), allowing purge air to flow through mix chamber nozzle (N).

See page 16 for use of grease fitting (G).

Cutaway View

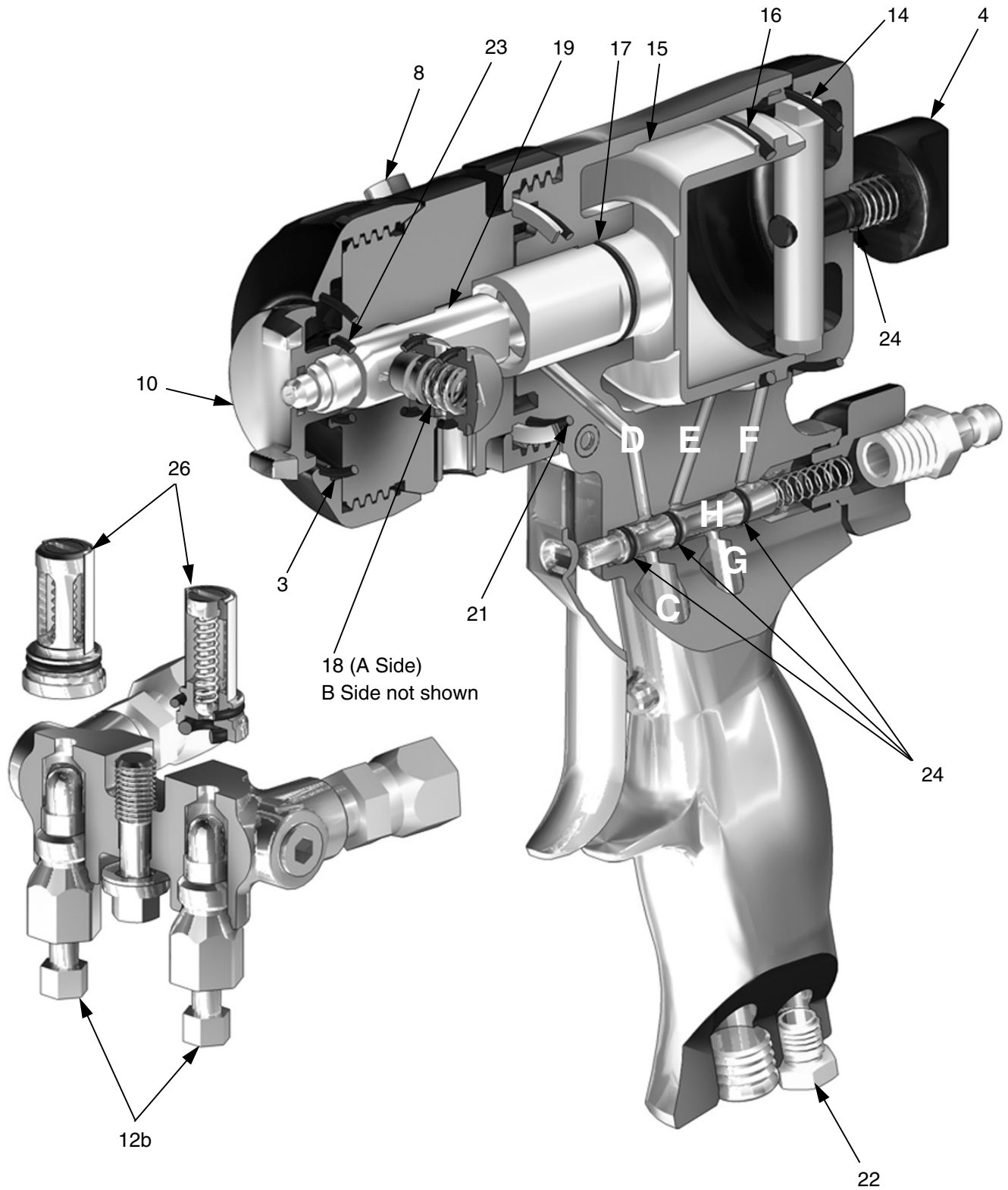

Repair

Tools Required



Tools needed for complete gun repair:

- adjustable wrench
- flat head screwdriver (included)
- 1/8 in. (3 mm) diameter rod
- 5/16 hex nut driver (included)

Lubrication

Liberal lubricate all o-rings, seals, and threads. Lubricate threads and outside of lock ring (11). See page 45 to order lubricant.

Remove Front End

 WARNING

Read warnings, page 7. Proper attachment of front end is critical. Do not operate gun if front end is loose or lock ring is not snug against handle.

1. Follow **Pressure Relief Procedure**, page 17.
2. **Flush Gun**, page 21.

CAUTION
If lock ring (R) is stuck due to material buildup, do not force it by turning entire front end. Locating tabs (Z) may break off. Soak front of gun in solvent to soften cured material and free lock ring.

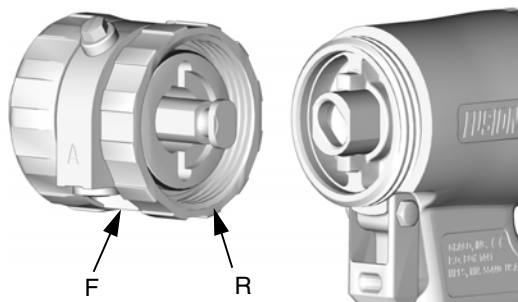
3. Unscrew lock ring (R) until front end of gun is loose. Turn fluid housing (F) 1/8 turn counterclockwise. Unscrew lock ring completely and remove front end of gun.



T12416A

Attach Front End

⚠ WARNING



Read warnings, page 7. Proper attachment of front end is critical. Do not operate gun if front end is loose or lock ring is not snug against handle.

1. Engage piston safety lock, page 12.



TI2409A

2. Push on air cap (C) until it is flush with front of gun. This ensures that mix chamber is all the way back.

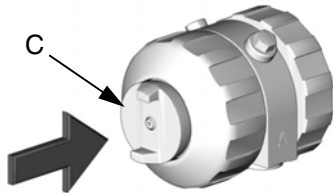

TI2422A

3. Check that o-ring (21) is in position. Liberally lubricate o-ring, threads of lock ring (R) and handle (H), and outside of lock ring. Orient front end (F) as required for desired fluid manifold mounting (bottom mounting is shown). Insert keyed end (W) of mix chamber in socket (X). Screw lock ring onto handle as far as possible by hand.

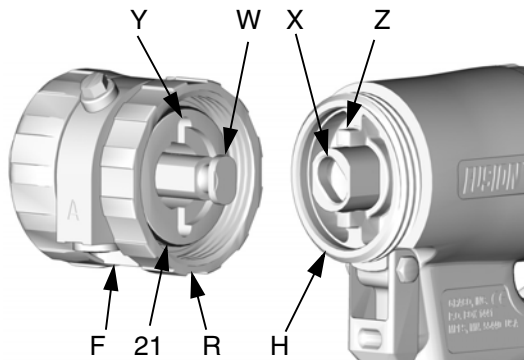

TI2416A

4. Turn fluid housing 1/8 turn clockwise to engage slots (Y) and tabs (Z). Push on front end to ensure it is properly seated. Continue screwing lock ring (R) onto handle (H) very securely. When properly assembled, lock ring is snug against handle.

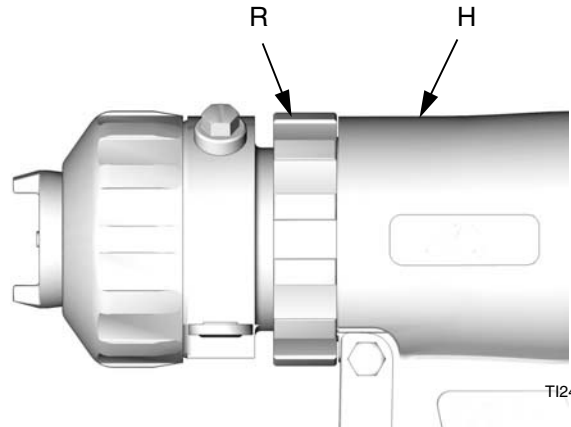

TI2423A

Mix Chamber and Side Seal Cartridges

See page 3 for available mix chamber sizes.

1. Follow **Pressure Relief Procedure**, page 17.
2. Remove fluid manifold (M). Leave air connected.

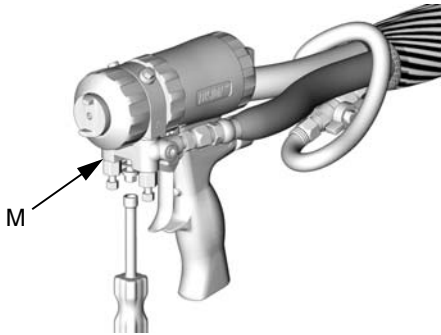

3. Flush gun to remove residual A and B components, page 21. Follow **Pressure Relief Procedure**, page 17.
4. Disconnect air.



5. **Remove Front End**, page 28.

6. Remove air cap (10) and retaining ring (9). Inspect o-ring (3) inside retaining ring.

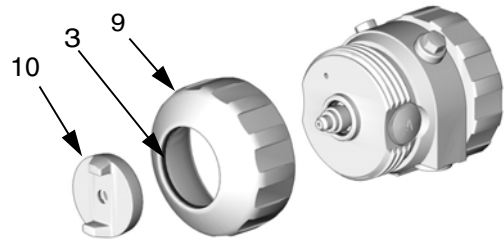

<p>CAUTION</p> <p>To prevent cross-contamination of side seal cartridges, do not interchange A component and B component parts. The A component cartridge is marked with an A.</p>

7. Pull out side seal cartridges (18). Also inspect o-ring (24) on cleanoff air valve (8).

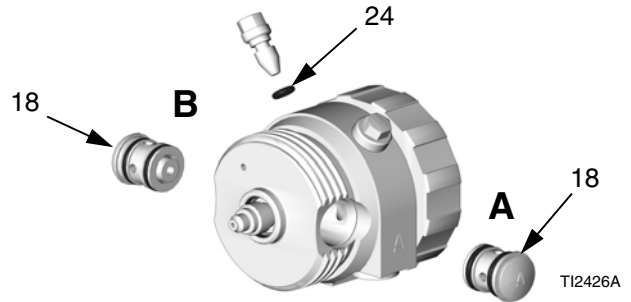

Continued on page 31.

- Pull mix chamber (19) out rear of fluid housing. Inspect for damage and clean ports, page 22. Inspect o-ring (23) in front of fluid housing.

CAUTION
To prevent cross-contamination of the gun's wetted parts, mix chamber is marked with an A and a notch (N) on back edge. Be sure the A side of mix chamber is on the A side of gun.

- Apply thin coat of lubricant to mix chamber (19). Install mix chamber. Etched **A** and notch (**N**) must be on same side as **A** on fluid housing. Mix chamber is keyed to fit in fluid housing.

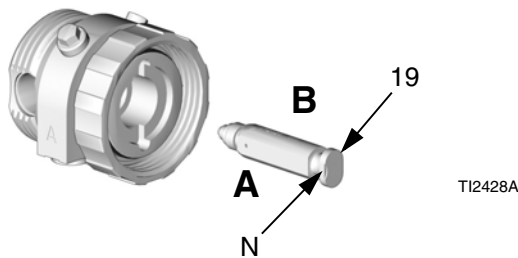

CAUTION
To prevent cross-contamination of side seal cartridges, do not interchange A component and B component parts. The A component cartridge is marked with an A.

- Carefully inspect side seal cartridge o-rings and surfaces. Replace worn or damaged parts. Liberally lubricate o-rings (18d, 18e) and reassemble. Press on side seal (18c) to check proper spring (18b) operation.

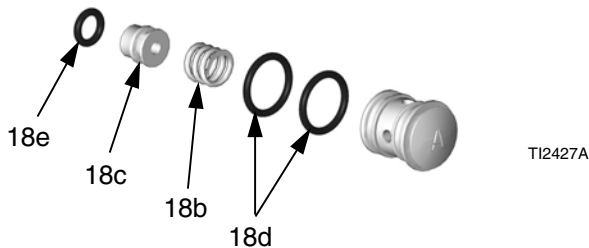

- Liberally lubricate and reinstall side seal cartridges (18).

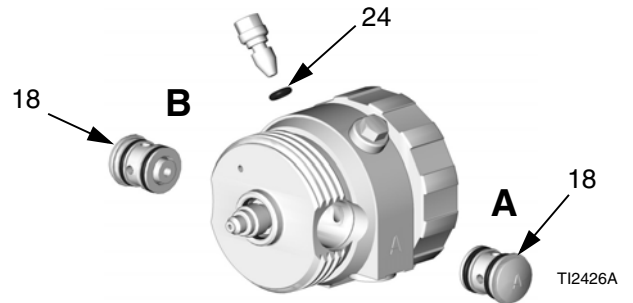

- Lubricate all threads and reinstall retaining ring (9). Install air cap (10).

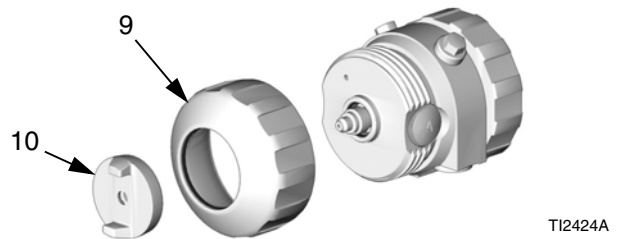

- Attach Front End**, page 29.

- Connect air, and trigger the gun a few times to check for leaks. If either check valve pops out of its seated position, there is a poor fluid seal on that side of the mix chamber or side seal/cartridge components. Correct the problem before attaching the fluid manifold.

- Attach fluid manifold. Connect air. Return gun to service.

Check Valves

 Before disassembling, press on ball (26c) to test check valve for proper movement and spring action.

1. Follow **Pressure Relief Procedure**, page 17.
2. Remove fluid manifold (M). Leave air connected. **Clean Fluid Manifold**, page 21.

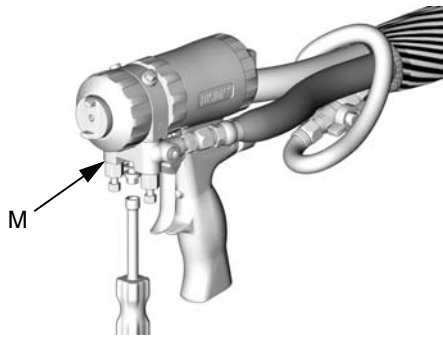

TI2543A

3. Flush gun to remove residual A and B components, page 21. Follow **Pressure Relief Procedure**, page 17.
4. Disconnect air.



TI2540A

CAUTION

To prevent cross-contamination of the check valves, do not interchange A component and B component parts. The A component check valve is marked with an A.

5. Pry out check valves (26) at notch.

WARNING



Read warnings, page 7. Damaged check valve o-rings (26f, 26g) may result in external leakage. Replace o-rings if any damage is seen.

6. Slide filter (26d) off. Clean and inspect parts. Thoroughly inspect o-rings (26f, 26g). If necessary, remove screw (26b) and disassemble entire check valve.

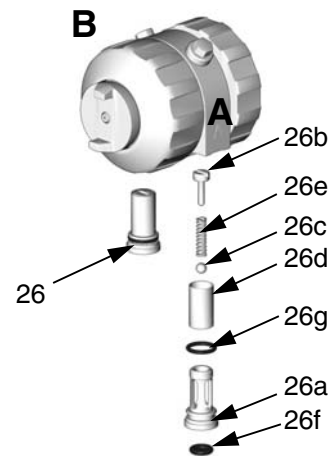

TI2429A

7. Reassemble check valves. Screw (26b) should be flush (within 1/16 in. or 1.5 mm) of housing (26a) surface. Liberally lubricate o-rings (26f, 26g) and carefully reinstall in fluid housing.
8. Attach fluid manifold. Connect air. Return gun to service.

Piston

1. Follow **Pressure Relief Procedure**, page 17.
2. Disconnect air (D) and remove fluid manifold (M).

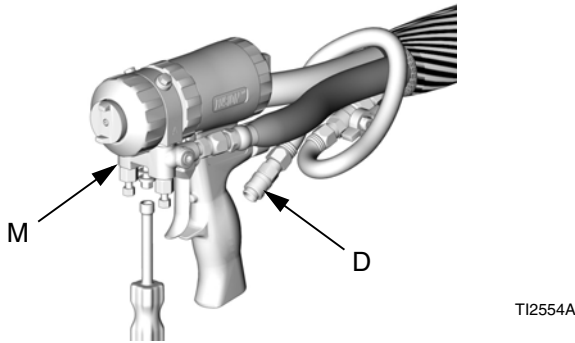

3. **Remove Front End**, page 28.
4. Unscrew cylinder cap (5) and inspect o-ring (14).

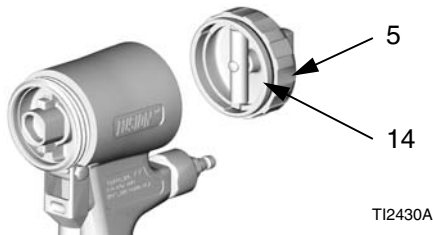

5. Push piston shaft to remove piston (15). Inspect piston o-ring (16) and shaft o-ring (17).

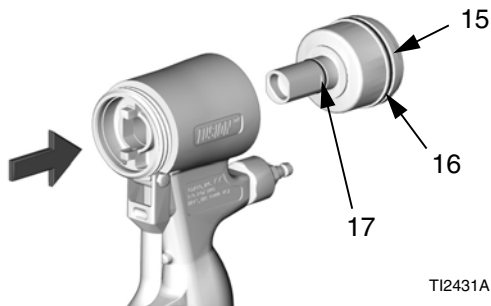

6. Liberally lubricate piston o-rings. Reinstall piston. Shaft is keyed for proper assembly. Push firmly to seat piston.

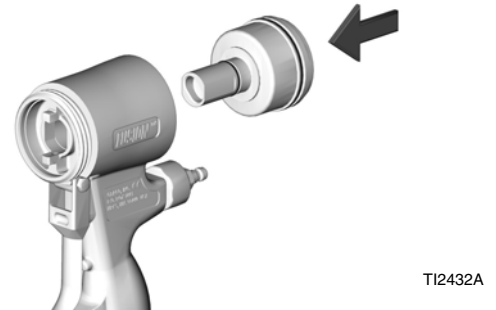

7. Install cylinder cap (5).



8. **Attach Front End**, page 29.
9. Attach fluid manifold. Connect air. Return gun to service.

Piston Safety Lock

1. Follow **Pressure Relief Procedure**, page 17.
2. Disconnect air (D) and remove fluid manifold (M).

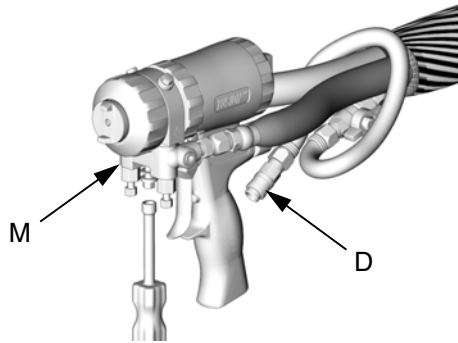

TI2554A

3. Unscrew cylinder cap (5). Hold piston stop (28) with wrench and unscrew from safety lock (4). Inspect spring (30) and o-rings (14, 24).

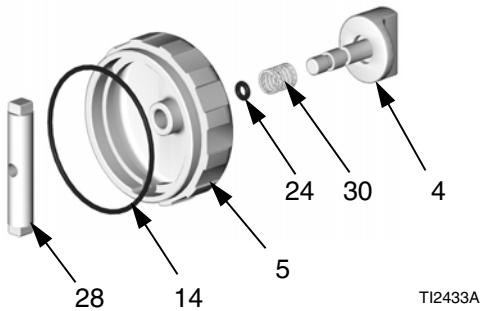

TI2433A

4. Liberally lubricate o-rings and reassemble. Clean threads with solvent or alcohol. Apply medium-strength Loctite® or equivalent to threads on stop (28) and reassemble.
5. Attach fluid manifold. Connect air. Return gun to service.

Air Valve

1. Follow **Pressure Relief Procedure**, page 17.
2. Disconnect air (D) and remove fluid manifold (M).

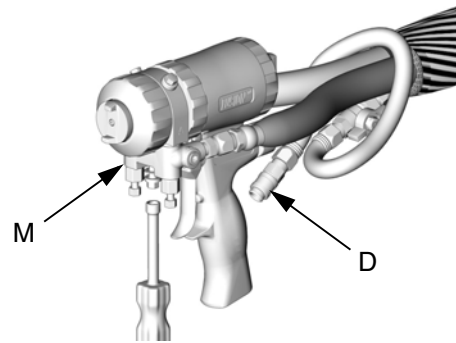

TI2554A

3. Unscrew air valve plug (2) and remove spring (31). Using a small diameter tool, push spool (32) out from front. Inspect o-rings (24).

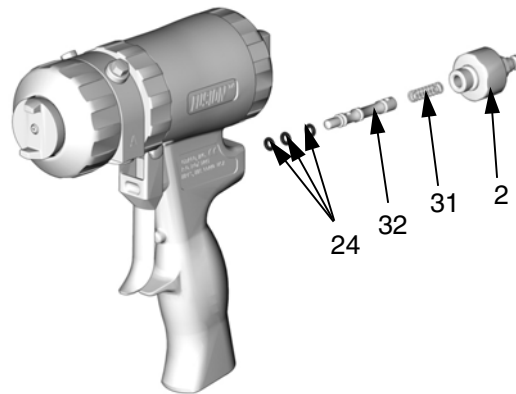

TI2434A

4. Liberally lubricate o-rings and reassemble. Torque plug (2) to 125-135 in-lb (14-15 N•m).
5. Attach fluid manifold. Connect air. Return gun to service.

Notes



A series of horizontal lines for writing, starting from the first line below the pencil icon and continuing down to the bottom of the page.

Parts

Round Pattern Gun Shown; see page 38 for additional parts and detail views

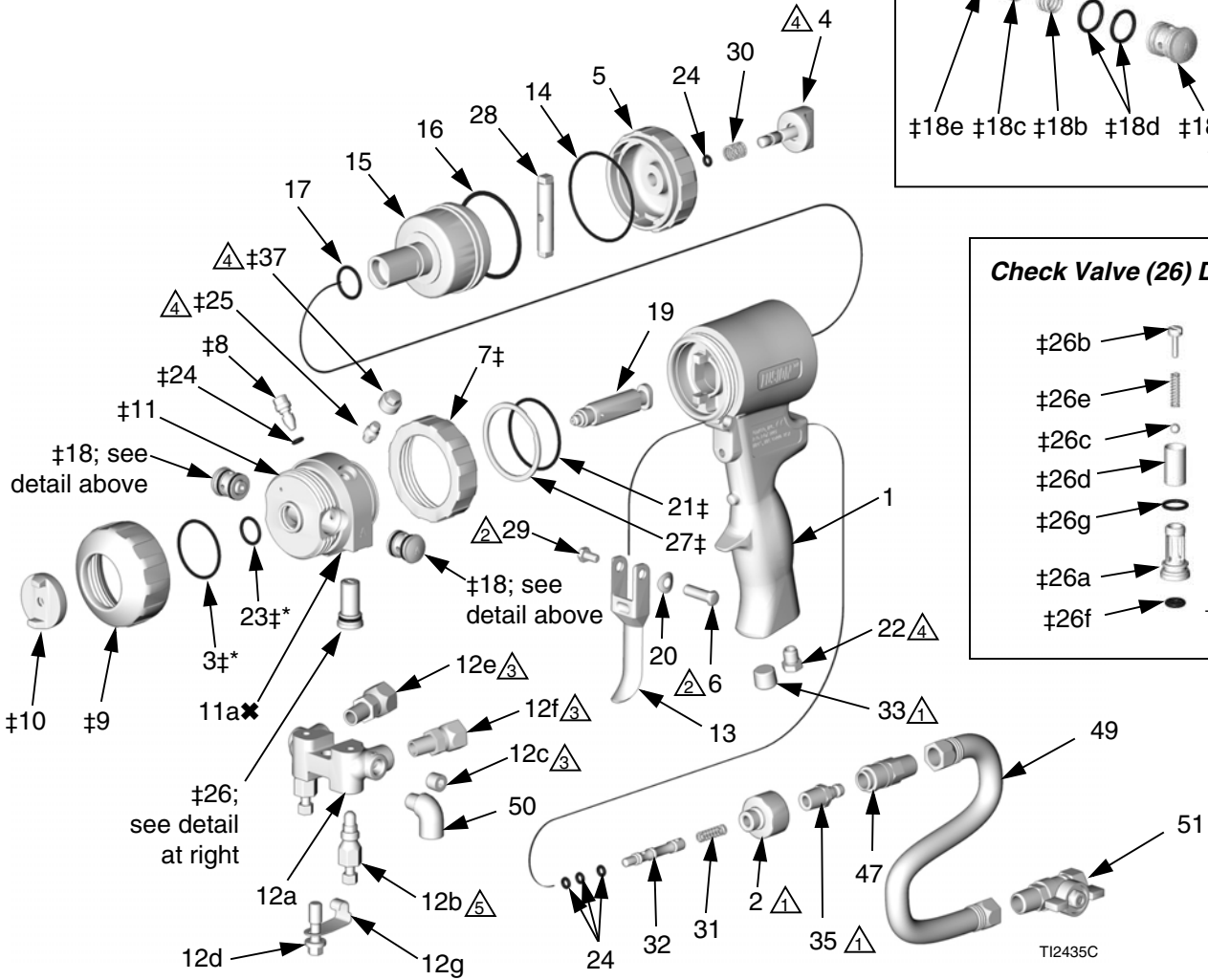

1 Torque to 125-135 in-lb (14-15 N•m).

2 Torque to 20-30 in-lb (2.3-3.4 N•m).

3 Torque to 235-245 in-lb (26.6-27.7 N•m).

4 Torque to 35-45 in-lb (4-5 N•m).

5 Torque to 32-40 ft-lb (43-54 N•m).

Ref. No.	Part No.	Description	Qty	Ref. No.	Part No.	Description	Qty
1	15K365	HANDLE	1	21†*	248132	O-RING; package of 6	1
2	15B208	PLUG, air valve	1	22	119626	MUFFLER	1
3‡	248137	O-RING; PTFE; package of 6	1	23‡*	248131	O-RING; package of 6	1
4★	15B206	LOCK, safety	1	24‡*★	246354	O-RING; package of 6	1
5★	15B204	CAP, cylinder	1	25‡	100846	FITTING, grease	1
6	192272	PIN	1	26‡	246731	VALVE, check, A side; includes 26a-26g	1
7‡	15B215	RING, lock	1		246352	VALVE, check, B side; includes 26a-26g	1
8‡	15B223	VALVE, cleanoff air	1	26a‡†		HOUSING	1
9‡	15B211	RING, retaining	1	26b‡†	15B214	SCREW; 5/16-18 x 1/2 in. (13 mm)	1
10‡	15B210	AIR CAP; for round pattern guns	1	26c‡	257420	BALL; carbide; package of 10	1
	15B801	AIR CAP; for flat pattern guns; not included in Front End Replacement Kit 246361; see Detail Views , page 38	1	26d‡		SCREEN; see page 40	1
◆	15D973	AIR CAP, for spatter pattern gun; not included in Front End Replacement Kit 246361; see Detail Views , page 38	1	26e‡	117490	SPRING	1
11‡	246491	HOUSING, fluid	1	26f‡*	248133	O-RING, check valve face; package of 6	1
11a★	248860	. KIT, thread insert, fusion	1	26g‡*	248129	O-RING, check valve housing; package of 6	1
12	246012	MANIFOLD, fluid, 2-hose; includes 12a-12g	1	27‡	116550	RING, retaining	1
	249523	MANIFOLD, fluid, 4-hose; includes 12a, 12b, 12d-12g, 50; see Detail Views , page 38	1	28★	15B205	STOP, piston	1
12a†		. MANIFOLD	1	29	203953	SCREW; 10-24 x 3/8 in. (10 mm)	1
12b	246356	. VALVE, fluid	2	30★	114070	SPRING	1
12c	100139	. PLUG, pipe; 1/8-27 npt	2	31	117485	SPRING	1
12d	15B221	. BOLT; 5/16-24	1	32	15B202	SPOOL, valve	1
12e	117634	. SWIVEL, B side; 1/8 npt(m) x no. 6 JIC(f); for 2-hose manifold	1	33	100721	PLUG, pipe; 1/4-18 npt; round and flat pattern guns only	1
	117634	. SWIVEL, B side; 1/8 npt(m) x no. 6 JIC(f); for 4-hose manifold; see Detail Views , page 38	2	35	117509	QUICK-DISCONNECT, male, air; 1/4 npt(m); round and flat pattern guns only	1
12f	117635	. SWIVEL, A side; 1/8 npt(m) x no. 5 JIC(f); for 2-hose manifold	1	36▲	222385	CARD, warning; not shown	1
	117635	. SWIVEL, A side; 1/8 npt(m) x no. 5 JIC(f); for 4-hose manifold; see Detail Views , page 38	2	37‡	15B689	COVER, grease fitting	1
12g	15B993	. SPRING, ring, lock	1	39	FTxxxx	TIP, flat; see Flat Tip Kits , page 40	1
13	15B209	TRIGGER	1	40*	246360	O-RING; PTFE; flat tip models only; package of 3; See Flat Pattern Guns , page 39	1
14*★	248136	O-RING, cylinder cap; package of 6	1	43	117661	WISE, pin; dual reversible chucks; see Supplied Tools , page 38	1
15	15B203	PISTON	1	46	117792	GREASE GUN; not shown	1
16*	248135	O-RING, piston; package of 6	1	47	117510	COUPLER, air line	1
17*	248134	O-RING, piston shaft; package of 6	1	49	15B772	HOSE, air; 1/4 npsm (fbe); 18 in. (0.46 m)	1
18‡	246349	CARTRIDGE, seal, A side, SST; includes 18a-18e	1	50	112307	ELBOW, street; 1/8 npt (m x f); round and flat pattern guns only	2
	246350	CARTRIDGE, seal, B side, SST; includes 18a-18e	1	51	15B565	VALVE, ball; 1/4 npt (m x f); round and flat pattern guns only	1
18a†		. CARTRIDGE BODY	1				
18b	117491	. SPRING	1				
18c*†		. SEAL KIT; see page 43	1				
18d*	248130	. O-RING, cartridge body; package of 6	1				
18e*	248128	. O-RING, side seal; package of 6	1				
19		CHAMBER, mix, round; see Round Pattern Guns , page 39	1				
		CHAMBER, mix, flat; see Flat Pattern Guns , page 39	1				
20	15C480	WASHER, wave	1				



See **Detail Views**, page 38, for additional parts.

* These parts are only available in repair kits. To select a kit, refer to page 40.

† These parts are not available singly.

‡ Included in Front End Replacement Kit 246361.

★ For date code B17 or prior, see manual 310767.

▲ Included in Safety Stop Assembly 248064 (includes 1 of item 24).

◆ Replacement Danger and Warning labels, tags, and cards are available at no cost.

◆ Included in Spatter Tip Kit 248414 (see page 38).

Ref. No.	Part No.	Description	Qty	Ref. No.	Part No.	Description	Qty
52	15B817	MANIFOLD, gun flush; round and flat pattern guns only	1	58◆	15D972	RETAINER, tip; spatter pattern gun only	1
53	117642	NUT DRIVER, hex; 5/16	1	59◆	15D971	TIP; spatter pattern gun only	1
54	118575	SCREWDRIVER; 1/8 blade	1	60◆	248019	SEAL, package of 5; spatter pattern gun only.	1
55▲	172479	TAG, warning; not shown	1	61❖	15F240	ADAPTER, stud wall	1
56▲	15D235	SIGN, instruction; not shown	1	62❖	15F854	PACKING, tip; stud wall	1
57	117773	GREASE CARTRIDGE; 3 oz; not shown; MSDS sheet available at www.graco.com	1	63❖	15F241	CAP, air; stud wall	1
				64❖	FTM979	TIP, flat; stud wall	1

- ▲ Replacement Danger and Warning labels, tags, and cards are available at no cost.
- ◆ Included in Spatter Tip Kit 248414.
- ❖ Included in Stud Wall Foam Kit 249421.

Detail Views

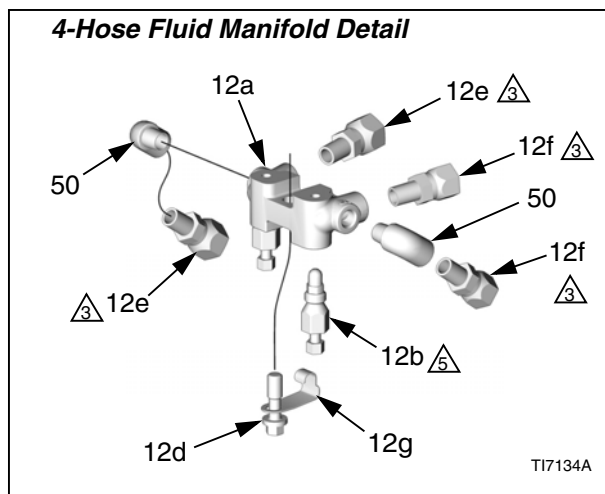
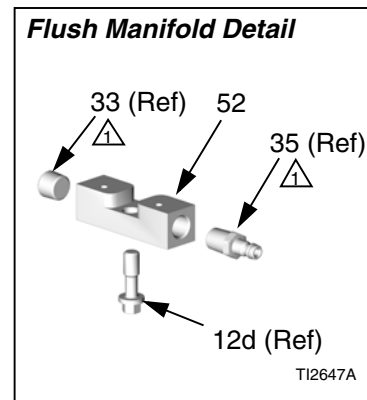
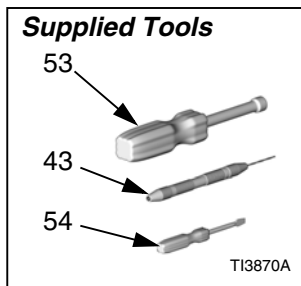
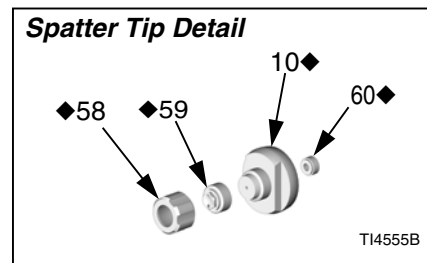
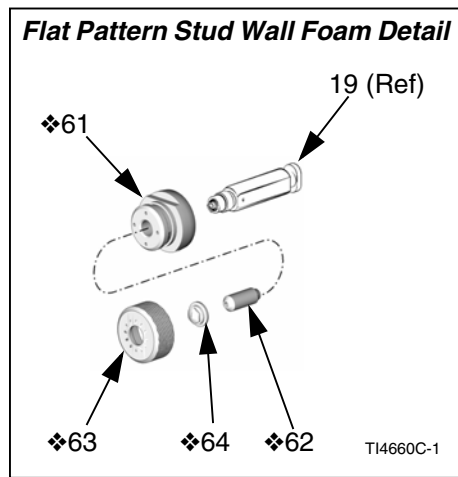
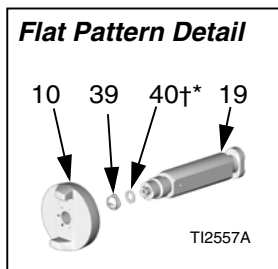

- △1 Torque to 125-135 in-lb (14-15 N•m).
- △3 Torque to 235-245 in-lb (26.6-27.7 N•m).
- △5 Torque to 32-40 ft-lb (43-54 N•m).

Mix Chamber Kits

Round Pattern Guns

Mix Chamber Kit (includes drill bits)	Nozzle Orifice Size	Nozzle Drill Bit Size, in. (mm)	Impingement Port Size	Impingement Port Drill Bit Size, in. (mm)	Counterbore Size	Counterbore Drill Bit Size, in. (mm)
AR2020	0.042	#58 (1.00)	0.020	#76 (0.50)	0.060	#53 (1.50)
AR2929	0.052	#55 (1.30)	0.029	#69 (0.70)	0.060	#53 (1.50)
AR3737	0.052	#55 (1.30)	0.037	#63 (0.94)	N/A	N/A
AR4242	0.060	#53 (1.50)	0.042	#58 (1.00)	N/A	N/A
AR4747	0.0635	1/16 (1.59)	0.0469	#56 (1.18)	N/A	N/A
AR5252	0.070	#50 (1.75)	0.052	#55 (1.30)	N/A	N/A
AR6060	0.086	#44 (2.15)	0.060	#53 (1.50)	N/A	N/A
AR7070	0.094	3/32 (2.35)	0.070	#50 (1.75)	N/A	N/A
AR8686	0.116	#32 (2.90)	0.086	#44 (2.15)	N/A	N/A

Non 1:1 Ratio Round Mix Chamber Kits

Mix Chamber Kit (includes drill bits)	Nozzle Orifice Size	Nozzle Drill Bit Size, in. (mm)	Impingement Port Size	Impingement Port Drill Bit Size, in. (mm)	Counterbore Size	Counterbore Drill Bit Size, in. (mm)
AR2232	0.094"	0.047 (1.2)	0.024" 0.0325"	#74, .023 (.57) #67, .032 (.81)	0.061"	#53, .0595 (1.5)
AR2942	0.053"	#55 (1.3)	0.043" 0.031"	#58, .042 (1.07) #69 .029 (.74)	0.061"	#53, .0595 (1.5)
AR3729	0.053"	#55 (1.3)	0.038" 0.031"	#63, .037 (.94) #69, .029 (.74)	0.061"	#53, .0595 (1.5)

Flat Pattern Guns

Mix Chamber Kit (includes drill bits and o-ring)	Ref. No. 40†, O-ring	Nozzle Orifice Size	Nozzle Drill Bit Size, in. (mm)	Impingement Port Size	Impingement Port Drill Bit Size, in. (mm)	Counterbore Size	Counterbore Drill Bit Size, in. (mm)
AF2020	246360	0.094	3/32 (2.35)	0.020	#76 (0.50)	0.060	#53 (1.50)
AF2929	246360	0.094	3/32 (2.35)	0.029	#69 (0.70)	0.060	#53 (1.50)
AF4242	246360	0.094	3/32 (2.35)	0.042	#58 (1.00)	N/A	N/A
AF5252	246360	0.094	3/32 (2.35)	0.052	#55 (1.30)	N/A	N/A

Non 1:1 Ratio Flat Mix Chamber Kits

Mix Chamber Kit (includes drill bits)	Ref. No. 40†, O-ring	Nozzle Orifice Size	Nozzle Drill Bit Size, in. (mm)	Impingement Port Size	Impingement Port Drill Bit Size, in. (mm)	Counterbore Size	Counterbore Drill Bit Size, in. (mm)
AF2033	246360	0.094"	3/32 (2.35)	0.035" 0.021"	#66, .033 (0.84) #76 .020 (.51)	0.061	#53, .0595 (1.50)
AF2942	246360	0.094"	3/32 (2.35)	0.042" 0.031"	#58, .042 (1.07) #69 .029 (.74)	0.061	#53, .0595 (1.50)

† Available only in flat mix chamber kits or in 246360 multi-pack kit.

Mix Chamber Part No. Reference Guide

Sample part no. AR4242:

AR	42	42
AR=Air purge round pattern	A orifice size (.042 in.)	B orifice size (.042 in.)
AF=Air purge flat pattern		

Flat Tip Kits

Ref. No. 39, Flat Spray Tip	Pattern Size, in. (mm)
FT0424	low flow, 8-10 (203-254)
FT0438	medium flow, 8-10 (203-254)
FT0624	low flow, 12-14 (305-356)
FT0638	medium flow, 12-14 (305-356)
FT0838	medium flow, 16-18 (406-457)
FT0848	high flow, 16-18 (406-457)

Flat Tip Part No. Reference Guide

Sample part no. FT0848:

FT	08	48
FT=Flat tip	x2=pattern length (8x2=16 in.)	Equivalent orifice diameter size (.048 in.)

Gun Repair Kits

Read the chart left to right and top to bottom to find the quantity of each part in the kits.

Ref. No.	Bulk O-ring Kits, (qty)	246347 Side Seal Cartridge O-ring Kit	246348 Side Seal Kit	246351 Check Valve O-ring Kit	246355 Complete O-ring Kit
3	248137 (6)				1
14	248136 (6)				1
16	248135 (6)				1
17	248134 (6)				1
18c			2		
18d	248130 (6)	4			4
18e	248128 (6)	2	2		2
21	248132 (6)				1
23	248131 (6)				1
24	246354 (6)				5
26f	248133 (6)			2	2
26g	248129 (6)			2	2
40	246360 (3)				

Check Valve Filter Screen Kits

Kits include 10 filter screens.

80 mesh filter screen is standard with gun.

246357 40 mesh (.015 in., 375 micron)

246358 60 mesh (.010 in., 238 micron)

246359 80 mesh (.007 in., 175 micron)









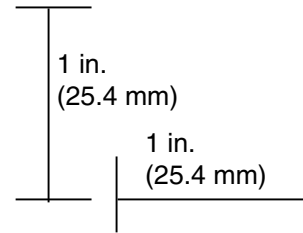

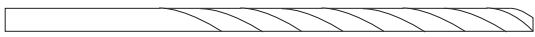
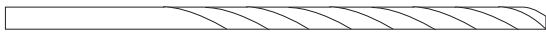
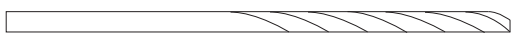

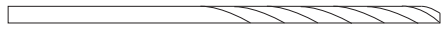
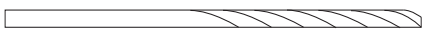
Drill Bit Kits

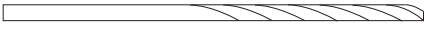
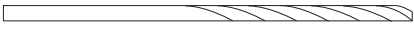
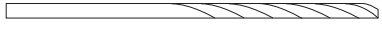
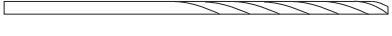
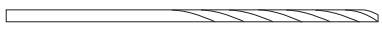

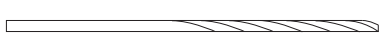









For cleaning gun ports and orifices. Illustrations are for diameter comparison. Actual length may vary.



Not all sizes are used with your gun.



Kit Part No.	Qty in Kit	Drill Bit Size			Illustration
		nominal	in.	mm	
249115	6	1/8	.125	3.18	
246623	3	#32	0.116	2.90	
246810	3	7/64	0.109	2.77	
246813	3	#39	.099	2.51	
246624	3	3/32	.094	2.39	
246812	3	#43	.089	2.26	
246625	3	#44	.086	2.18	
248639	6	2.15 mm	.085	2.15	
249114	6	#45	.082	2.08	
246811	3	2 mm	.079	2.00	
246626	6	#50	.070	1.78	
249113	6	#52	0.64	1.63	
248893	6	1/16	.062	1.59	
246627	6	#53	.060	1.52	
249112	6	1.45 mm	.057	1.45	
246809	6	#54	.055	1.40	
246628	6	#55	.052	1.32	
249764	6	1.20 mm	.047	1.20	
246814	6	#56	.046	1.18	

Kit Part No.	Qty in Kit	Drill Bit Size			Illustration
		nominal	in.	mm	
246629	6	#58	.042	1.07	
246808	6	#60	.040	1.02	
248640	6	#61	.039	0.99	
248618	6	#63	.037	0.94	
248891	6	#66	.033	0.84	
246807	6	#67	.032	0.81	
246630	6	#69	.029	0.74	
248892	6	#70	.028	0.71	
246815	6	#73	.024	0.61	
276984	6	#74	.023	0.57	
246631	6	#76	.020	0.51	
246816	6	#77	.018	0.46	
246817	6	#81	.013	0.33	

Drill Bit Kit

119386

Kit includes 20 cleanout drill bits ranging in sizes of #61 through #80.

Air Purge Handle Cleanout Drill Kit

248969

Kit includes all 5 drill bits of extra long length needed to clean out the air passages in the Air Purge gun handle and fluid housing. See **Clean Passages**, page 22.

Accessories

Wide Pattern Mix Chamber Kits

Kits include mix chamber and cleanout drills. To spray larger diameter patterns than the standard mix chambers.

Kit Part No.	Pattern Diameter at 24 in. (609.6 mm) to target in (mm)	Equivalent flow to mix chamber size	Nozzle Drill Bit Size in (mm) *	Impingement Drill Bit Size in. (mm) *
AW2222	8 (203.2)	NA	.047 (1.20)	#74, .022 (0.56)
AW2828	15 (381.0)	Ref. AR2929	1/16, .062 (1.59)	#70, .028 (0.71)
AW3333	15 (381.0)	Ref. AR3737	#53, .060 (1.52)	#66, .033 (0.84)
AW3939	16 (406.4)	Ref. AR4242	#50, .070 (1.78)	#61, .039 (0.99)
AW4646	18 (457.2)	Ref. AR5252	.085 (2.15)	#56, .046 (1.17)
AW5757	18 (457.2)	Ref. AR6060	#43, .089 (2.26)	1.45 mm, .057 (1.45)
AW6464	22 (563.9)	Ref. AR7070	7/64, .109 (2.77)	#52, .064 (1.63)
AW8282	24 (609.6)	Ref. AR8686	1/8, .125 (3.18)	#45, .082 (2.08)

Stainless Steel Side Seal Kits

Kits include a packing o-ring for each stainless steel seal.

Kit Part No.	Description	No. of Seals Per Kit
246348	SEAL KIT, SST	2
277299	SEAL KIT, SST	50

Polycarbally Side Seal Kits

Kits include a packing o-ring for each polycarbally seal. The optional high wear, non-metallic polycarbally seals are for alternate fluids.

Kit Part No.	Description	No. of Seals Per Kit
249990	SEAL KIT, Polycarbally	2
277298	SEAL KIT, Polycarbally	50

Extension Tip Kits

Kits include extension, flat tip seal and round tip seal, cleanout drill bit, and instructions.

Requires 248020 Extension Tip Air Cap Kit (order separately).

Kit Part No.	Hole Diameter x Length, in. (mm)	Recommended Mix Chambers	Spray Distance, ft (m) *	Pattern Diameter, in. (mm) *
248010	.042 x 0.50 (1.06 x 12.7)	AR2020/AF2929	15 (4.57)	10 (254)
248011	.052 x 0.50 (1.32 x 12.7)	AR2929/AF2929	12 (3.66)	10 (254)
248012	.060 x 0.50 (1.52 x 12.7)	AR4242/AF4242	12 (3.66)	12 (305)
248013	.070 x 0.50 (1.78 x 12.7)	AR5252/AF5252	8 (2.44)	20 (508)
248014	.042 x 1.0 (1.06 x 25.4)	AR2020/AF2929	15 (4.57)	10 (254)
248015	.052 x 1.0 (1.32 x 25.4)	AR2929/AF2929	12 (3.66)	8 (203)
248016	.060 x 1.0 (1.52 x 25.4)	AR4242/AF4242	12 (3.66)	8 (203)
248017	.070 x 1.0 (1.78 x 25.4)	AR5252/AF5252	8 (2.44)	8 (203)

* Measured with less than 8 in. (203 mm) drop in stream center at 1200 psi (8.4 MPa, 84 bar) static pressure.

Extension Tip Seal Kits

Kits include 5 seals.

Kit Part No.	Description
248018	Flat Extension Tip Seal Kit
248019	Round Extension Tip Seal Kit

Extension Tip Air Cap Kit

248020

Includes air cap for use with extension tip kits 248010-248017.

Flat Pattern Stud Wall Kit

249421

To spray high-flow, flat patterns. For use with flat mix chambers only: AF2929, AF4242, AF5252. Includes adapter parts and cleanout tool.



- Flat pattern mix chamber not included. Order separately.
- Optional tip FTM762 available for lower flow and smaller pattern application.

Hose Adapter Kits

246944

To connect non-Graco gun to Graco heated hose.

248029

To connect Graco Fusion gun to non-Graco D-gun hose set.

246945

To connect Graco Fusion gun to non-Graco heated hose.

Spatter Conversion Kit

248414

To convert Fusion air purge gun to spray, round pattern only, large droplet, low overspray applications. Includes air cap, tip, retainer, seal, and cleanout drill bits.

Pour Nozzle Kit

248528

To convert air purge gun for pour applications. Includes nozzle, seals, tubing, and cleanout drill bits.

Gun Cover

244914 Covers

Keeps gun clean while spraying. Pack of 10.

Lubricant for Gun Rebuild

248279, 4 oz (113 gram) [10]

High adhesion, water resistant, lithium-based lubricant. MSDS sheet available at www.graco.com.

Grease Cartridge for Gun Shutdown

248280 Cartridge, 3 oz [10]

Specially formulated low viscosity grease flows easily through gun passages, to prevent 2 component curing and keep fluid passages clean. See page 16.

Flushing Manifold

15B817 Manifold Block

See ref. no. 52, page 36.

Solvent Flush Canister Kit

248139, 1 qt (0.95 liter) Solvent Cup

Complete with 15B817 Flushing Manifold to flush gun with solvent. Portable for remote flushing. See manual 309963.



TI4165a

Solvent Flush Pail Kit

248229 5.0 gal. (19 liter) Pail

Includes flush manifold with individual A and B shutoff valves, and air regulator. See manual 309963.

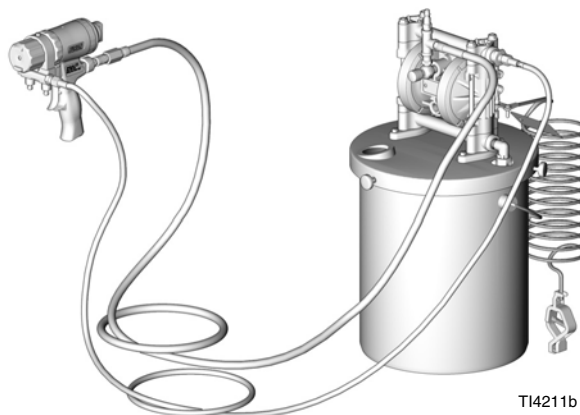

TI4211b

Tip Cleanout Tool

15D234

Designed to fit CeramTip internal dome and flat tip slits.

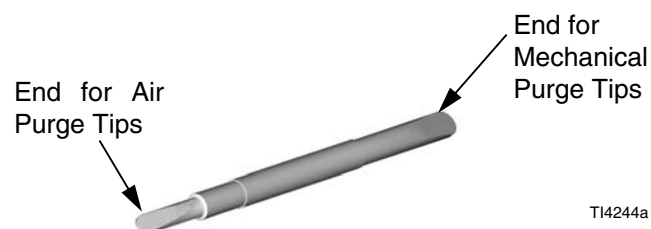

TI4244a

Gun Cleaning Kit

15D546

Kit includes 11 tools and brushes to clean the gun.

Circulation Manifold

246362

Attach to gun fluid manifold to enable preheating of hose. See manual 309818.

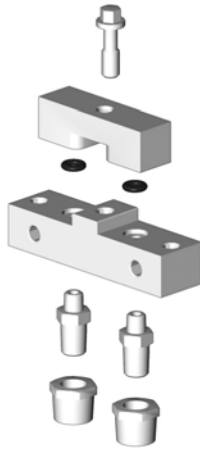

TI3877a

Gun Grips

Applicator's comfort level with a spray gun is an essential part of the spray foam and polyurea installation process. The applicator's fatigue level can dramatically affect the pattern and productivity of a project. 3M™ Gripping Material Technology is designed to:

- Reduce fatigue
- Provide comfort
- Give thermal protection

Gun Grip Kit

Graco Gun Grips are designed to be used on Fusion® A, CS, or Probler® P2 Guns.

Kit Part No.	Qty in Kit
17G542	10 Pack
17G543	50 Pack
17G544	100 Pack

Technical Data

Category	Data
Maximum Fluid Working Pressure	3500 psi (24.5 MPa, 245 bar)
Minimum Air Inlet Pressure	80 psi (0.56 MPa, 5.6 bar)
Maximum Air Inlet Pressure	130 psi (0.9 MPa, 9 bar)
Air Flow Range	See chart below
Typical Flow Rate of Round Pattern Guns	See chart page 3.
Typical Flow Rate of Flat Pattern Guns	See chart page 6.
Maximum Fluid Temperature	200° F (94° C)
Air Inlet Size	1/4 npt Quick Disconnect Nipple
A Component (ISO) Inlet Size	-5 JIC; 1/2-20 UNF
B Component (Resin) Inlet Size	-6 JIC; 9/16-18 UNF
Sound Pressure	81.1 dB(A), using AR5252 at 100 psi (0.7 MPa, 7 bar)
Sound Power, measured per ISO 9416-2	91.0 dB(A), using AR5252 at 100 psi (0.7 MPa, 7 bar)
Dimensions	7.5 x 8.1 x 3.3 in. (191 x 206 x 84 mm)
Weight	2.5 lb (1.1 kg)
Wetted Parts	Aluminum, stainless steel, carbon steel, carbide, chemically resistant o-rings

All other brand names or marks are used for identification purposes and are trademarks of their respective owners.

Air Flow Data in scfm (m³/min)

Air Pressure (detriggered) psi (MPa, bar)	Mix Chamber Sizes							
	AR2020	AR2929	AR3737	AR4242	AR5252	AR6060	AR7070	AR8686
80 (0.56, 5.6)	0.8 (.022)	1.4 (.039)	2.0 (.056)	2.6 (.073)	3.7 (0.104)	4.6 (0.129)	5.7 (0.160)	7.1 (0.200)
100 (0.7, 7)	0.9 (.025)	1.7 (.048)	2.9 (.081)	3.1 (.087)	4.6 (0.129)	5.7 (0.160)	7.1 (0.200)	8.8 (0.246)
130 (0.9, 9)	1.2 (.034)	2.3 (.064)	3.2 (.090)	4.1 (0.115)	5.9 (0.165)	7.3 (0.204)	9.2 (0.258)	11.3 (0.316)

Graco Standard Warranty

Graco warrants all equipment referenced in this document which is manufactured by Graco and bearing its name to be free from defects in material and workmanship on the date of sale to the original purchaser for use. With the exception of any special, extended, or limited warranty published by Graco, Graco will, for a period of twelve months from the date of sale, repair or replace any part of the equipment determined by Graco to be defective. This warranty applies only when the equipment is installed, operated and maintained in accordance with Graco's written recommendations.

This warranty does not cover, and Graco shall not be liable for general wear and tear, or any malfunction, damage or wear caused by faulty installation, misapplication, abrasion, corrosion, inadequate or improper maintenance, negligence, accident, tampering, or substitution of non-Graco component parts. Nor shall Graco be liable for malfunction, damage or wear caused by the incompatibility of Graco equipment with structures, accessories, equipment or materials not supplied by Graco, or the improper design, manufacture, installation, operation or maintenance of structures, accessories, equipment or materials not supplied by Graco.

This warranty is conditioned upon the prepaid return of the equipment claimed to be defective to an authorized Graco distributor for verification of the claimed defect. If the claimed defect is verified, Graco will repair or replace free of charge any defective parts. The equipment will be returned to the original purchaser transportation prepaid. If inspection of the equipment does not disclose any defect in material or workmanship, repairs will be made at a reasonable charge, which charges may include the costs of parts, labor, and transportation.

THIS WARRANTY IS EXCLUSIVE, AND IS IN LIEU OF ANY OTHER WARRANTIES, EXPRESS OR IMPLIED, INCLUDING BUT NOT LIMITED TO WARRANTY OF MERCHANTABILITY OR WARRANTY OF FITNESS FOR A PARTICULAR PURPOSE.

Graco's sole obligation and buyer's sole remedy for any breach of warranty shall be as set forth above. The buyer agrees that no other remedy (including, but not limited to, incidental or consequential damages for lost profits, lost sales, injury to person or property, or any other incidental or consequential loss) shall be available. Any action for breach of warranty must be brought within two (2) years of the date of sale.

GRACO MAKES NO WARRANTY, AND DISCLAIMS ALL IMPLIED WARRANTIES OF MERCHANTABILITY AND FITNESS FOR A PARTICULAR PURPOSE, IN CONNECTION WITH ACCESSORIES, EQUIPMENT, MATERIALS OR COMPONENTS SOLD BUT NOT MANUFACTURED BY GRACO. These items sold, but not manufactured by Graco (such as electric motors, switches, hose, etc.), are subject to the warranty, if any, of their manufacturer. Graco will provide purchaser with reasonable assistance in making any claim for breach of these warranties.

In no event will Graco be liable for indirect, incidental, special or consequential damages resulting from Graco supplying equipment hereunder, or the furnishing, performance, or use of any products or other goods sold hereto, whether due to a breach of contract, breach of warranty, the negligence of Graco, or otherwise.

FOR GRACO CANADA CUSTOMERS

The Parties acknowledge that they have required that the present document, as well as all documents, notices and legal proceedings entered into, given or instituted pursuant hereto or relating directly or indirectly hereto, be drawn up in English. Les parties reconnaissent avoir convenu que la rédaction du présente document sera en Anglais, ainsi que tous documents, avis et procédures judiciaires exécutés, donnés ou intentés, à la suite de ou en rapport, directement ou indirectement, avec les procédures concernées.

Graco Information

For the latest information about Graco products, visit www.graco.com.

For patent information, see www.graco.com/patents.

TO PLACE AN ORDER, contact your Graco distributor or call to identify the nearest distributor.

Phone: 612-623-6921 or Toll Free: 1-800-328-0211 Fax: 612-378-3505

All written and visual data contained in this document reflects the latest product information available at the time of publication. Graco reserves the right to make changes at any time without notice.

Original instructions. This manual contains English. MM 309550

Graco Headquarters: Minneapolis

International Offices: Belgium, China, Japan, Korea

**GRACO INC. AND SUBSIDIARIES • P.O. BOX 1441 • MINNEAPOLIS MN 55440-1441 • USA
Copyright 2002, Graco Inc. All Graco manufacturing locations are registered to ISO 9001.**

www.graco.com

Revision ZAM, August 2018